

# GE Consumer & Industrial Lighting

## ConstantColor® CMH® GU6.5

### 20 watt and 39 watt CMH® Our smallest Ceramic Metal Halide single-ended GU6.5 lamps

#### Highly efficient

Reduce energy costs by up to \$92.00 per lamp\* when using a 39-watt CMH® (Requires new fixture to replace a 120 watt halogen)  
4 times more lumens per watt than comparable incandescent or halogen lamps

#### Twist and Lock Base Design

Provides secure alignment  
Easy installation  
Robust base reduces annoying pin degradation

#### Color uniformity lamp-to-lamp

ConstantColor® CMH® lamps provide a consistent "white look" for color-critical applications such as retail display

#### Excellent color rendering

Up to 90 CRI for setting the desired look for the application

#### Long life

Up to 12,000 hour rated life provides for extended relamp cycles and reduced maintenance costs

#### Point source of light

Compact quartz envelope allows for terrific fixture optics to maximize system efficiency

\* @ 10¢kWh over life of the lamp



Uniform, Consistent Color  
Point Source for Design Flexibility



GE – Innovative,  
Energy-Saving Lighting



imagination at work

**R Warning:** This lamp can cause serious skin burn and eye inflammation from shortwave ultraviolet radiation if outer envelope of the lamp is broken or punctured, and the arc tube continues to operate. Do not use where people will remain for more than a few minutes unless adequate shielding or other safety precautions are used. Certain types of lamps that will automatically extinguish when the outer envelope is broken or punctured are commercially available.

# GE ConstantColor® CMH® GU6.5

## Product Information

Product Code	Description	ANSI Code
85086	CMH20T/U830GU6.5	M156
71484	CMH39T/U930GU6.5	M130
71487	CMH39T/U942GU6.5	M130

## Physical Characteristics

Lamp Wattage	20W	39W	39W
Bulb Designation	T4	T4	T4
Base Type	GU6.5 Twist & Lock	GU6.5 Twist & Lock	GU6.5 Twist & Lock
Burn Position	Universal	Universal	Universal
Rated Life	12,000 Hours	10,000 Hours*	12,000 Hours*
Initial Lumens	1,615	3,400	3,400
CCT	3,000K	3,000K	4,000K
CRI	81	88	90
Volts	90	90	95
Max. Base Temp.	250° C	350° C	350° C
Max. Bulb Temp.	400° C	550° C	550° C
LCL	30mm ± 2mm	30mm ± 2mm	30mm ± 2mm
MOL	52mm	52mm	52mm
Overall Length w/ Pins	56.7mm	56.7mm	56.7mm
Fixture Requirement	Enclosed	Enclosed	Enclosed
Max. Fixture Voltage-Rise	5 Volts	5 Volts	5 Volts
Ballast Requirement	ANSI M156	ANSI M130	ANSI M130

\*Initial life at launch. Life test continues to establish final rated life.

Dimension	Value
A	52 mm
B	12 mm
C	30 mm

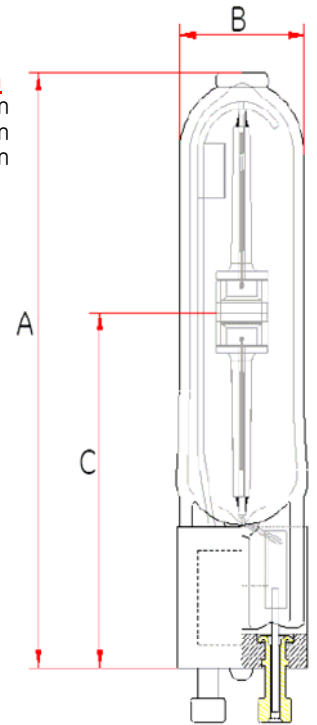

## Spectral Power Distribution

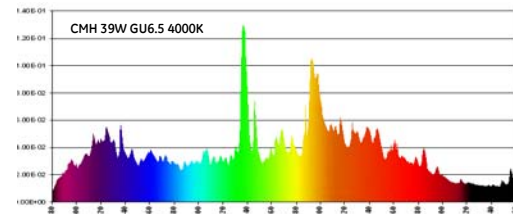
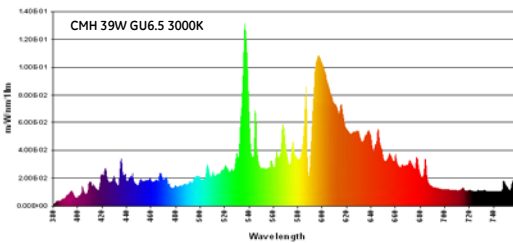
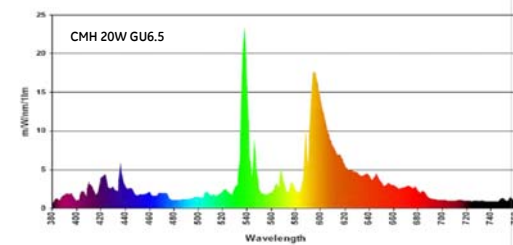

## Lamp Survival

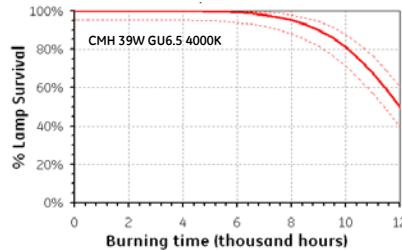
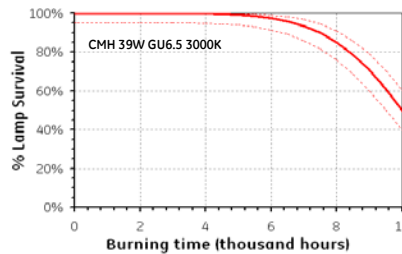
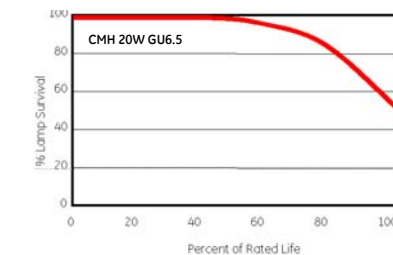

## Lumen Maintenance

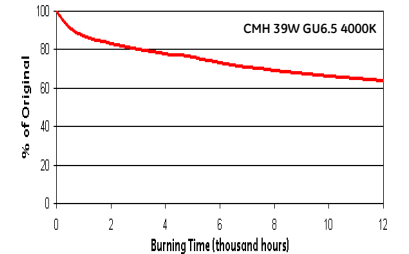
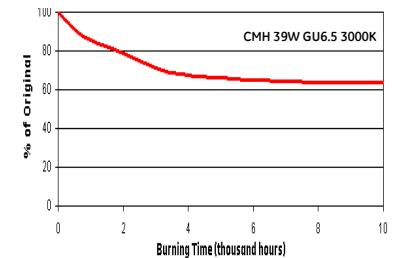
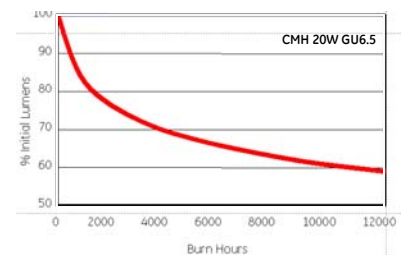

Information provided is subject to change without notice. Please verify all details with GE. All values are design or typical values when measured under laboratory conditions, and GE makes no warranty or guarantee, express or implied, that such performance will be obtained under end-use conditions.