

Application

The Power Cages's superior lumen package is ideal for replacing traditional metal halide high bay systems. Benefits include high efficiency, 95% lumen maintenance, improved color rendering, extended lamp life, multi-level switching, instant on, dimming and improved uniformity. Suggested mounting heights from 15' – 40' with primary applications including warehousing, commercial facilities, manufacturing facilities, open and stack aisle applications.

Description

The full body assembly accommodates either T5 or T8 lamps. Power Cage's heavy gauge housing is code gauge steel and all components are post painted with a glossy, high reflectance white paint. Sockets include secure positioning rotating collars.

Reflector Optics

The superior beam spread optic covers from narrow aisle lighting to open area general lighting. Choice of 95% specular reflector and 92% white reflector, which comes with a 25 year warranty.

Electrical

All ballasts are class P rated and UL/CUL listed. Our ballasts are also thermally protected, sound rated and tightly secured by mounting bolts.

Finish

The baked white enamel finish is electrostatically applied and post painted with a glossy, highly reflective and durable white paint.

Catalog Ordering Matrix

PC4	SA	3	32	UNI	H	
Series	Reflector Distribution	Lamp Quantity	Lamp Type	Voltage	Ballast Factor	Options
PC4 - 4 Foot	SA - Specular Aluminum	3	28 - (T8 28W)	UNI - (120-277)	H - (T8 High)	(See Below)
PC8 - 8 Foot	WA - White Aluminum	4	32 - (T8 32W)	120	N - (T8 Normal)	
		6	54 - (T5H0 54W)	277	L - (T8 Low)	
		8		347	V - (T5H0)	
				480		

OPTIONS

Power Cords

- 2P - 120V, 15A, 8' Power cord w/ straight blade plug
- 3P - 120V, 15A, 8' Power cord w/ twist lock plug
- 4T - 120V, 20A, 10' Power cord w/ twist lock plug
- 11P - 208V, 15A, 8' Power cord w/ straight blade plug
- 9T - 208V, 20A, 8' Power cord w/ twist lock plug
- 8P - 277V, 20A, 8' Power cord w/ straight blade plug
- 10P - 277V, 20A, 15' Power cord w/ straight blade plug
- 10T - 277V, 15A, 10' Power cord w/ twist lock plug
- 10T2 - 277V, 20A, 10' Power cord w/ twist lock plug
- 6C - 600V rated 6' Power cord only. No plug
- 10C - 600V rated 10' Power cord only. No plug
- 20C - 600V rated 20' Power cord only. No plug
- 6W - 600V rated 6' flexible metal conduit fixture whip
- 6C4 - 120V-300V 6' Power cord only, 4 wire. No plug
- 20C4 - 120V-600V 20' Power cord only, 4 wire. No plug
- 8T - 480V, 20A, 8' Power cord w/ L8-20 twist lock plug

Occupancy Sensors

- OS6 - Occupancy sensor w/ bracket for 15'+ mounting hgt.
- OS9 - Occupancy sensor w/ bracket for <15' mounting hgt.
- OSL - Occupancy sensor w/ bracket for 20'+ mounting hgt.

* Use a program rapid start ballast with occupancy sensor. TCP is not responsible for lamps failing prematurely due to an occupancy sensor being used with an instant start ballast.

Wire Guard

- NWG4 - No wire guard
- NWG8 - No wire guard

Emergency Ballasts

- B1 - 400 LMS 90 min
- B7 - 550 LMS 120 min
- B9 - 550 LMS 90 min
- B6 - 650 LMS 90 min
- B5 - 1350 LMS 90 min
- B3 - 3000 LMS 90 min
- BL5 - 700 LMS 90 min.
(For use with T5)
- BL6 - 1250 LMS 90 min.
(For use with T5)

Lamps Installed in Job Pack

- 730 - T8 Lamps Only
- 735 - T8 Lamps Only
- 741 - T8 Lamps Only
- 830 - T5 and T8 Lamps
- 835 - T5 and T8 Lamps
- 841 - T5 and T8 Lamps
- 850 - T5 and T8 Lamps
- 865 - T5 and T8 Lamps
- 830HL - T8 Lamps Only
- 835HL - T8 Lamps Only
- 841HL - T8 Lamps Only
- 850HL - T8 Lamps Only
- 865HL - T8 Lamps Only
- 830XHL - T8 Lamps Only
- 835XHL - T8 Lamps Only
- 841XHL - T8 Lamps Only
- 850XHL - T8 Lamps Only
- 865XHL - T8 Lamps Only

Special Mounting

- EZHANGER - 15' adjustable aircraft cable hanging kit
- HCB - Hub Connector Box - 3/4" Threaded Hub Mount
- 12Pendantkit - Mounting kit for 1/2" pendants
- 34Pendantkit - Mounting kit for 3/4" pendants
- LHKIT - Single Point Hook Mounting Kit complete

Fixture Color

- White - Standard Color
- Unless Specified

- Orange
- Green
- Blue
- Yellow
- Bronze
- Black
- Red

For Custom Color Please Provide RAL #

Catalog Number

Notes

Type

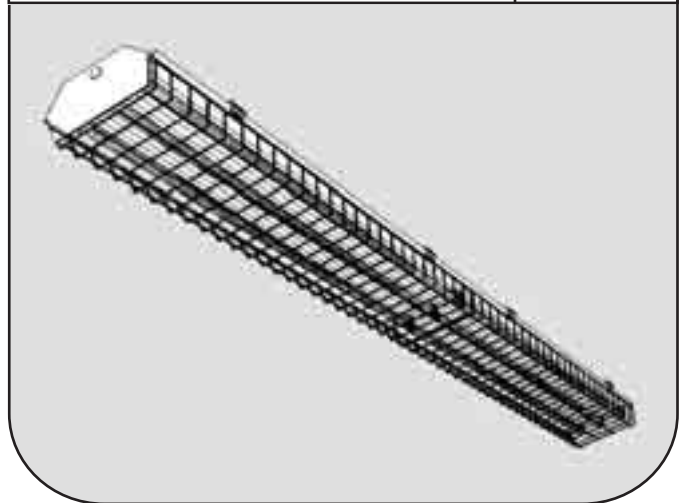

Power Cage T5 and T8 Series

Maintenance

No tools required for lamp and ballast access.

Warranty

One year warranty against defect in manufacturing

Installation

Suspension by chain, cable, hook or monopoint with appropriate accessories.

Listing

UL/CUL Listed - Suitable for damp locations.

TCP Linear Power Cage Fluorescent High Bay T8 / T5

Dimensions & Construction

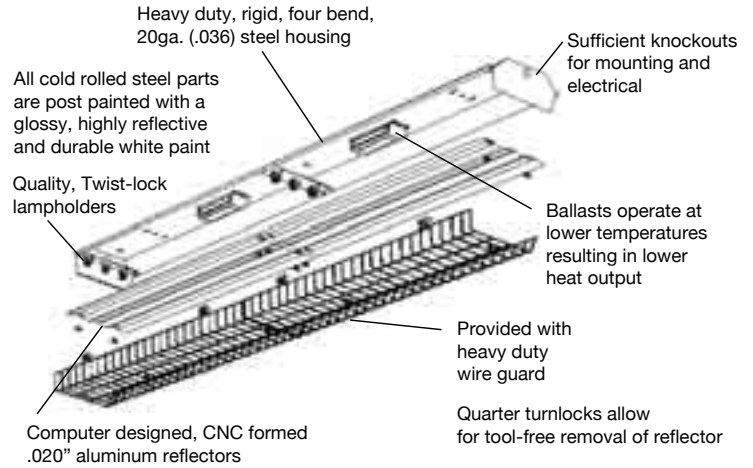
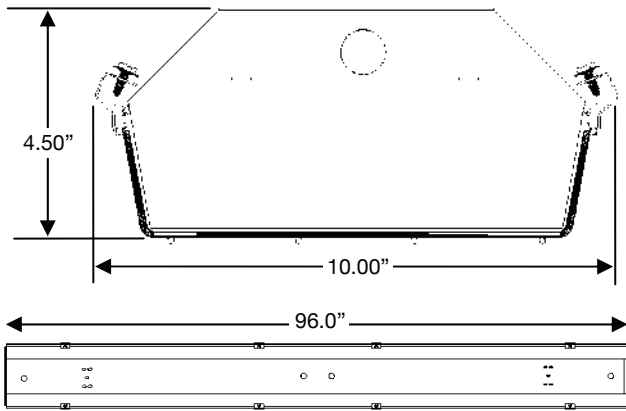

Photometric Report 1 x 4 Power Cage, 3-54W, 95% Specular Reflector

TCP Power Cage Luminaire with Enhanced Aluminum reflector, 3-54W lamps with lumen rating of 5000 lumens and one electronic ballast operating at 120 VAC and 178 watts.

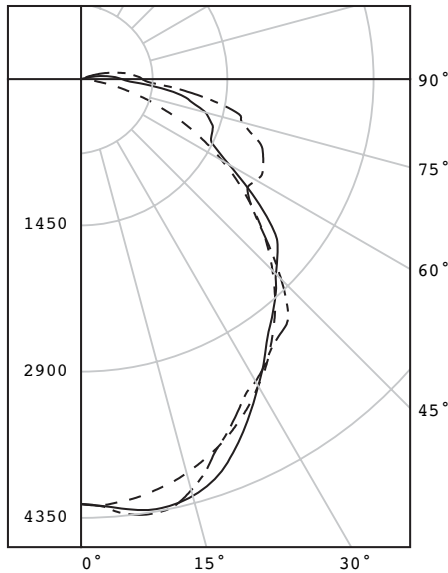

Candela Distribution

	0.0	22.5	45.0	67.5	90.0
0.0	4214	4214	4214	4214	4214
5.0	4211	4226	4270	4294	4312
15.0	4043	4194	4279	4264	4219
25.0	3726	3953	3830	3702	3657
35.0	3267	3464	3203	3271	3278
45.0	2685	2749	2732	2894	2806
55.0	1987	2046	2152	2030	2028
65.0	1243	1417	1420	1868	1992
75.0	533	696	1279	1565	1652
85.0	41	401	669	858	888
90.0	0	159	370	505	560

Zonal Lumen Summary

Zone	Lumens	% Lamp	% Fixt.
0-30	3345	25.1	25.2
0-40	5418	40.6	40.9
0-60	9412	70.5	71.0
0-90	12883	96.5	97.2
90-120	371	2.8	2.8
90-150	371	2.8	2.8
90-180	371	2.8	2.8
0-180	13254	99.3	100.0

Total Luminaire Efficiency = 99.3%

Luminance Data in Candela/Square Meter

	0.0	45.0	90.0
45.0	13543	13994	14153
55.0	12429	13456	12685
65.0	10674	12194	17106
75.0	7524	18055	21627
85.0	1681	16253	19977

Paint Reflectance = 0.78 S/MH = 1.21

Spacing Criteria (0) = 1.2

Spacing Criteria (90) = 1.2