

**INTERMATIC**<sup>®</sup>  
Providing a brighter solution.™

**WEATHERPROOF**

ENERGY CONTROLS

PROFESSIONAL LIGHTING

PROFESSIONAL LIGHTING

PROFESSIONAL LIGHTING

PROFESSIONAL LIGHTING

PROFESSIONAL LIGHTING



While In-Use Cover

**WP3100C**

Flexi-Guard While In-Use Cover

SURGE PROTECTION

SURGE PROTECTION

SURGE PROTECTION

POOL & SPA

POOL & SPA

POOL & SPA

POOL & SPA

POOL & SPA



# WP3100C

Flexi-Guard While In-Use Cover

Weatherproof While In-Use Cover

### APPLICATIONS

Provides an attractive, code compliant solution for protecting while in-use outdoor receptacles.

### SPECIFICATIONS

- Mounts Vertically or Horizontally
- Hidden Hinges
- Three patented inserts for GFCI, Duplex, Toggle and Single Receptacles
- Inserts include keyhole slots for 16 installation configurations
- Pre-adhered gasket
- Heavy-duty polycarbonate construction
- Clear Cover
- Gray Base
- Meets requirements for cold impact testing at -60° F (51°C)
- Lockable hasp for 1/8" shank lock

**Warranty:** Limited 1 year warranty

**Shipping weight:** 1 lbs.

**Agency Listing:** c  us

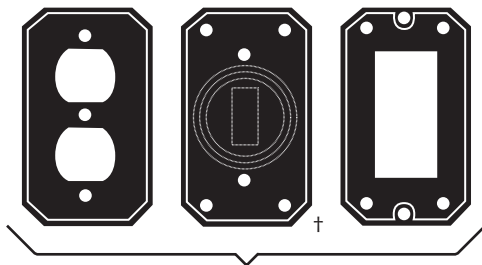

Single Gang Flexi-Guard Inserts

† Converts to toggle, 1-3/8"; 1-5/8"; 1-3/4", or 2-1/8" diameter round



**Intermatic, Inc.**  
7777 Winn Road  
Spring Grove, Illinois 60081-9698

**www.intermatic.com**  
Intermatic Customer Service: 815-675-7000  
(8 a.m. through 4:30 p.m. CST, Monday through Friday)

©2005 Intermatic, Inc.  
Printed in the U.S.A.

### PRODUCT FEATURES

- Complies with 2005 NEC® Article 406.8(B)(1): "15 and 20 Ampere, 125 and 250V receptacles installed in wet locations shall have an enclosure that is weatherproof whether or not the attachment plug cap is inserted"
- Easy to remove cord set exit ports



GFCI DEVICE SHOWN  
NOT INCLUDED

### DIMENSIONS

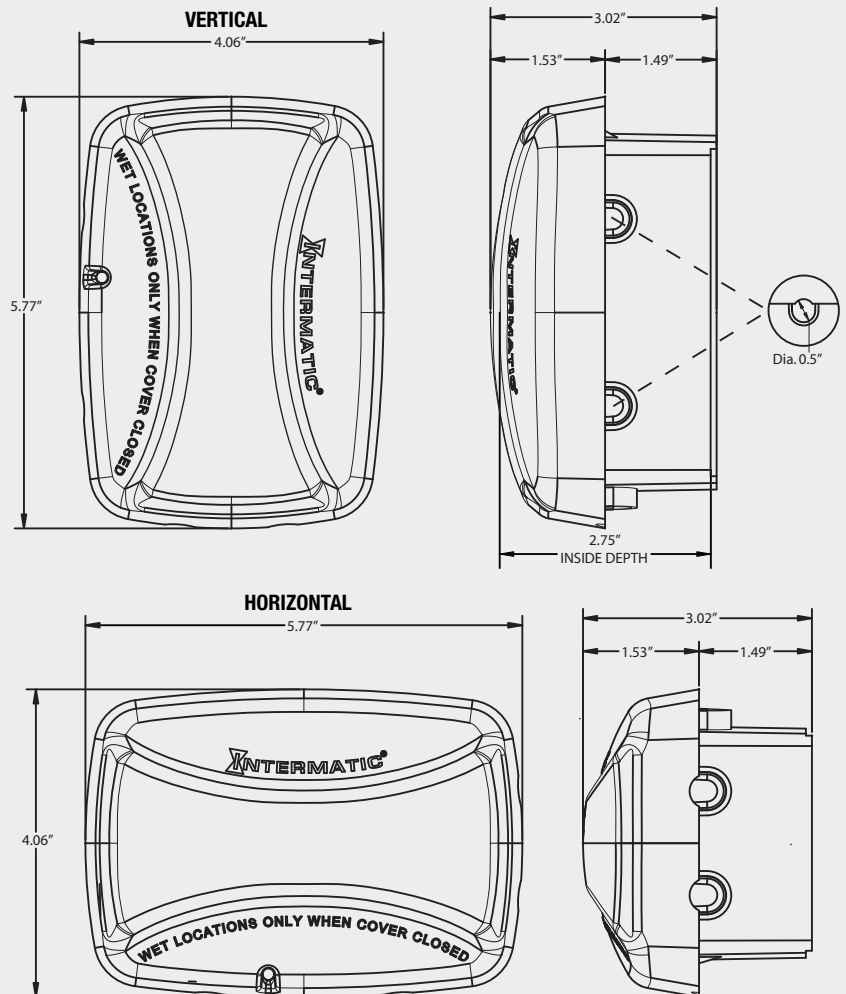

300WP10053