

Infrared Wall Mount Occupancy Sensor



The LOS-WIR wall-mounted passive infrared sensor is used in spaces with pendant fixtures, ceiling fans, or high ceilings (more than 12 ft./3.7 m). The sensor detects large body motions over 40 ft. (12 m) away, and smaller motions such as hand movements up to 25 ft. (7.6 m) away.

Features

- Intelligent, continually adapting sensor
- Passive infrared (PIR) sensing
- Excellent false tripping immunity
- Use in rooms with pendant fixtures and storage areas
- Flexible base mounting on wall or ceiling
- Aim and lock: base mount permits fast alignment
- Non-Volatile Memory: settings saved in protected memory are not lost during power outages
- 1,600 sq.ft. (488 m²) of coverage when used where the ceiling height is between 8 - 12 ft. (2.4 - 3.7 m)
- Affords choice of turning lights off or dimming to a preset level in the unoccupied state when integrated with a Lutron system.

Models Available

Cat. No.	Color	Coverage	Field of View
LOS-WIR-WH	White	1600 sq.ft. (288 m ²)	110°

Self-Adaptive Feature

Designed to meet the challenges found in a wide variety of spaces, the LOS-WIR works well in spaces with overhead fans and space heaters. Work areas, storage facilities, storerooms, indoor garages, and rooms with pendant fixtures are ideal. The internal microprocessor analyzes the information from the PIR technology and determines the optimum setting to use in order to properly cover the space.

The LOS-WIR identifies, records, and learns normal occupancy cycles of a space. Over an initial 4-week period, the sensor logs room occupancy for each 24-hour period. The information gathered by the sensor is used to automatically adjust the dual internal sensitivity bias threshold. This technology eliminates time-consuming adjustments and callbacks found in non-intelligent sensors.

Job Name:	Model Numbers:
Job Number:	

Specifications

Timer Settings

- Automatic mode: Continually adapting sensor automatically adjusts settings to the space
- Manual mode: 4 to 30 minutes
- Test mode: 8 seconds

Operating Environment

- Temperature: 32 to 104 °F (0 to 40 °C)
- Relative humidity: 0% to 95%, non-condensing
- For indoor use only

Power

- Operating voltage: 20 - 24 V_{DC}, PELV (Class 2: USA) low-voltage
- Operating current: 33 mA nominal
- Control output: 20 - 24 V_{DC} active high logic control signal with short-circuit protection, open collector when unoccupied
- UL and CUL listed

Dimensions

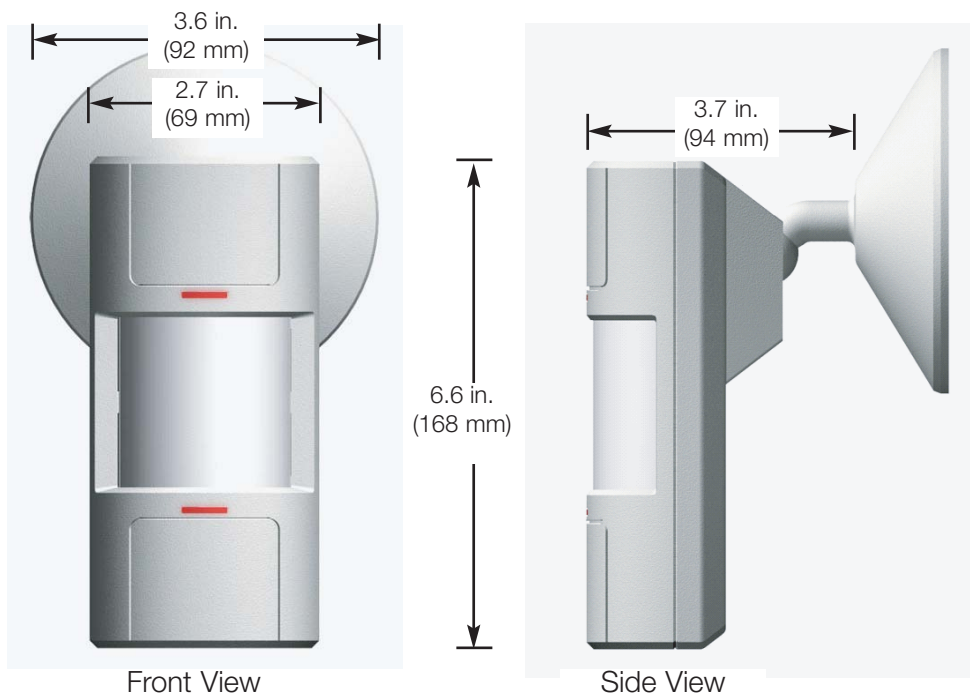

Job Name:	Model Numbers:
Job Number:	

Wiring

Note: Power pack may be required when interfaced to lighting control system; see below.

Single Sensor to System

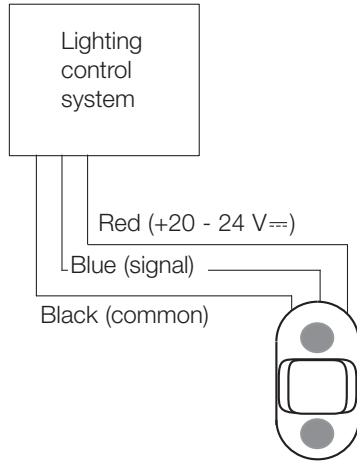

2 or More Sensors to System

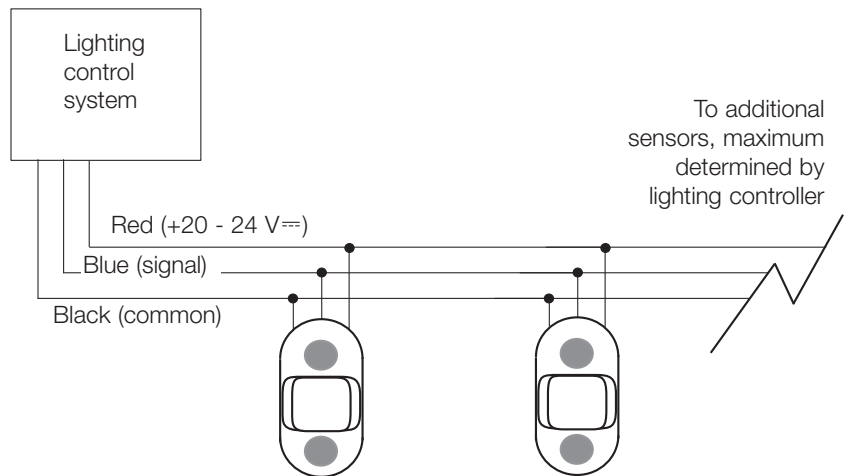

Power Supply Options

Lutron Lighting Control System

Digital microWATT™

EcoSystem®

GRAFIK 5000 / 6000 / 7000

GRAFIK Eye® 3000 / 4000

HomeWorks®

LCP128™

microWATT®

RadioRA®

RadioTouch®

Softswitch128®

Power Pack Required?

No

No

No, when used with seeTouch® wallstations with occupant sensor connections.

Yes

Yes

No, when used with seeTouch wallstations with occupant sensor connections.

No

Yes

No

No, when used with seeTouch wallstations with occupant sensor connections.

Job Name:	Model Numbers:
Job Number:	

Wiring: Stand-Alone Control

1 to 3 Sensors with Power Pack

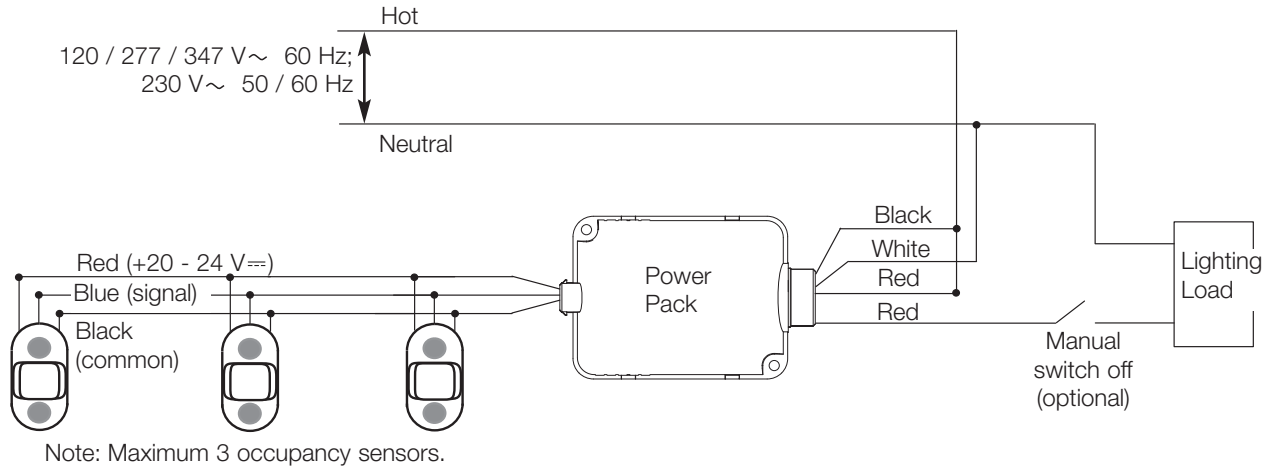

Switching Multiple Loads with Auxiliary Power Packs

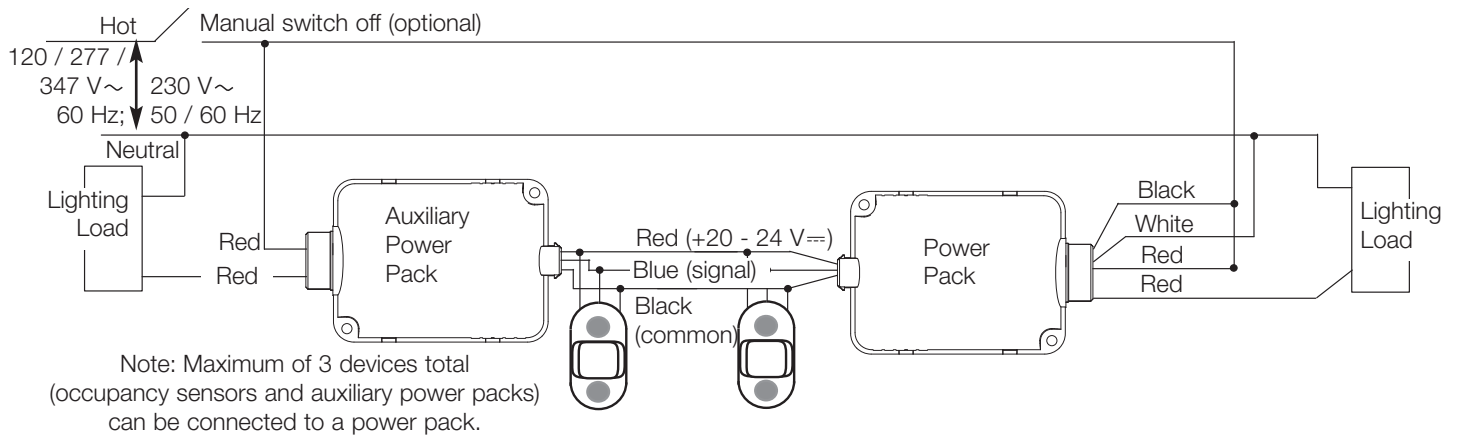

Job Name:	Model Numbers:
Job Number:	

Installation

Sensor Placement

- The occupant sensor must have an unobstructed view of the room. Do not mount behind or near tall cabinets, shelves, indirect hanging fixtures, etc.
- Keep the occupant sensor away from air flow from ventilation outlets, windows, fans, etc.
- Closely follow the diagrams shown concerning major and minor motion coverage. The sensor can detect major motion (such as a person taking a half-step) at a greater distance than it can detect minor motion (such as writing or typing at a desk).
- May not detect occupancy with no significant difference between ambient and body temperatures.

Range Diagram

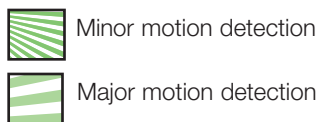
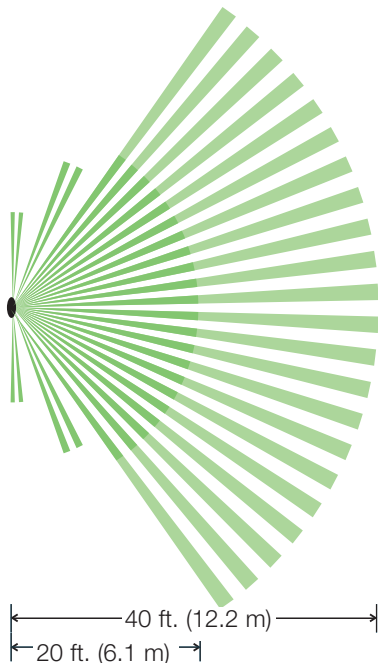

Sensor Placement

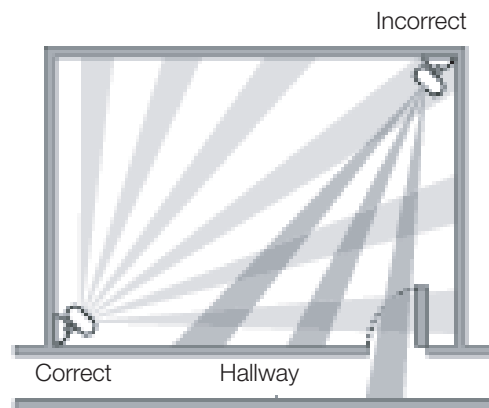

Job Name:	Model Numbers:
Job Number:	

Installation

Mounting

Mounting to Wall or Ceiling Tile

Redrill wiring routing hole and (2) mounting holes using Mounting Bracket as template. Route wires through wall and mounting bracket. Secure mounting bracket to wall/ceiling tile using mounting screws, nuts, and washers (included).

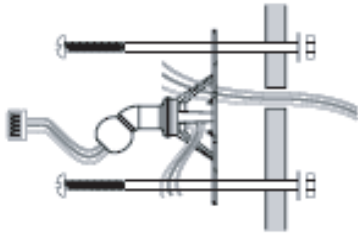

Mounting in Acoustic Ceiling Tile

Twist threaded mounting post onto Mounting Bracket. Drill through ceiling tile with assembly. Secure with washer and nut. Route wiring through Mounting Bracket and connect to wire harness. Snap bracket cover in place to conceal wiring and bracket.

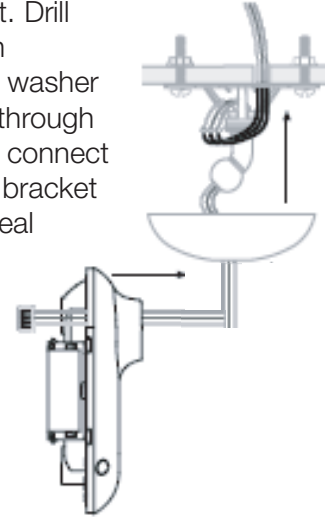

Either Method

Feed wiring harness through the back of the sensor body and out the exit slot. Snap sensor onto mounting post. Plug wiring harness into connector on the left side (opposite exit slot) and place wiring under wire tabs. Align sensor and tighten position locking screw.

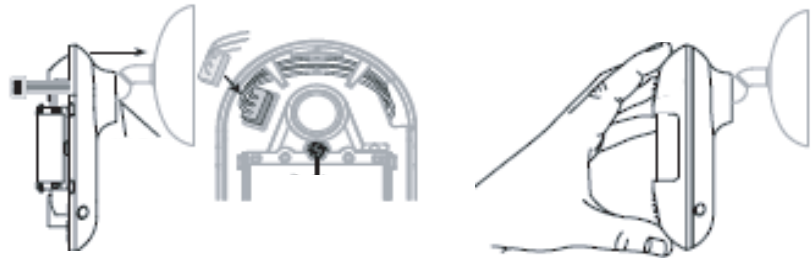

Wire Lengths

# Sensors	1	2	3	1	2	1
# Aux. PP	0	0	0	1	1	2
22 AWG	750 ft.	375 ft.	250 ft.	375 ft.	250 ft.	250 ft.
0.5 mm ²	365 m	180 m	120 m	90 m	120 m	120 m
20 AWG	1200 ft.	600 ft.	400 ft.	600 ft.	400 ft.	400 ft.
0.75 mm ²	730 m	365 m	240 m	365 m	240 m	365 m
18 AWG	2400 ft.	1200 ft.	800 ft.	1200 ft.	800 ft.	800 ft.

Mounting Plate Dimensions

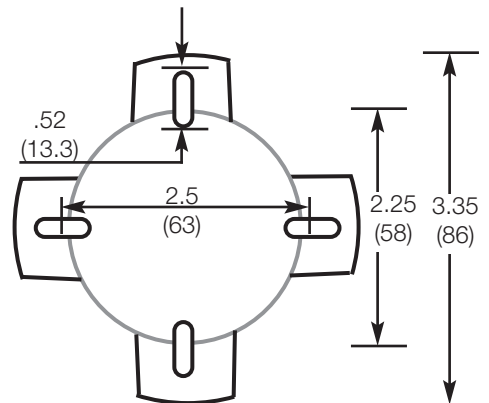

Measurements are in inches (mm)

Job Name:

Model Numbers:

Job Number:

Sensor Adjustments

Override Settings

		Off (Default)	On
A	1	<input type="checkbox"/> Automatic (Normal)	Manual lights on (Override)
	2	<input type="checkbox"/> Not used	Not used
	3	<input type="checkbox"/> LED on (Normal)	LED off
	4	<input type="checkbox"/> Retain Settings (Normal)	Any change resets learned settings

		Off		On	
B	1	<input type="checkbox"/> OFF } 8 min.	<input type="checkbox"/> OFF } 4 min.	<input type="checkbox"/> ON } 15 min.	<input type="checkbox"/> ON } 30 min.
	2	<input type="checkbox"/> OFF } min.	<input type="checkbox"/> ON } min.	<input type="checkbox"/> OFF } min.	<input type="checkbox"/> ON } min.
	3	<input type="checkbox"/> Auto Timer Adjust On		Auto Timer Adjust Off	
	4	<input type="checkbox"/> Auto Sensitivity Adjust On		Auto Sensitivity Adjust Off	

Factory Settings

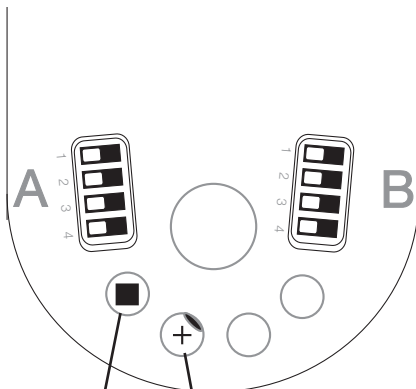

Timer Test Mode
 Push and Release:
 8 sec. test timer
 (resets to Normal
 after 1 hour)

Red: Infrared
 sensitivity
 75% default

Push and Hold (flash):
 Normal timer

Job Name:	Model Numbers:
Job Number:	