

The classic thin-profile linear-slide dimmer.

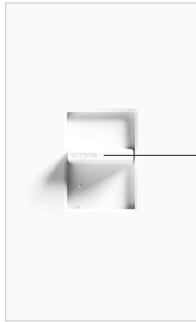

Select light level with slider; slide down to off

**Slide-to-off Dimmer**

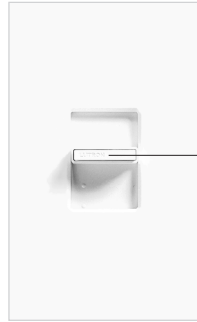

Select light level with slider; press on/off

**Preset Dimmer**

### PRODUCT FAMILY FEATURES

- Classic linear-slide dimmer with thin profile design
- Excellent for residential or commercial applications
- Intuitive operation—easy to use
- Slide-to-off and preset models available
- Enclosed heat sink for aesthetically pleasing appearance
- Multigang alignment for quick and easy installation
- Full family of products for most lighting sources, plus matching accessories and wallplates
- Now available for 277V Magnetic Low Voltage in 600VA and 1000VA ratings
- Metal, custom multi-gang and engraved wallplates available

### DIMENSIONS

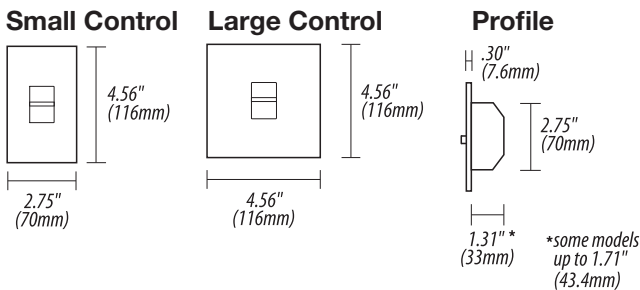

### SPECIFICATION SERIES STANDARD FEATURES



- Square Law Dimming
  - Power-failure memory
  - Captive linear slider
  - Electrostatic discharge tested
  - Heavy-duty components for surge protection and long product life
  - Voltage compensation
  - Superior RFI suppression
  - Accessible air-gap switch
  - Precise color matching
- Lutron controls are rated at 120VAC, 60Hz unless otherwise noted.

JOB NAME	AREA CONTROLLED
LOCATION	JOB NUMBER
TITLE	PAGE NO.

### CONTROLS AND ACCESSORIES

#### Slide-to-Off Dimmers

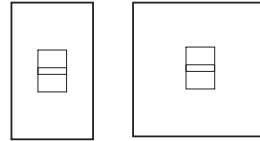

(Small Control)    (Large Control)

#### Preset Dimmers

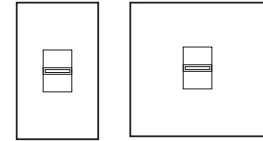

(Small Control)    (Large Control)

#### Omnislide Dimmers

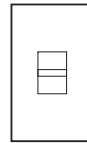

Two Location Dimming System

#### Linear-Slide Switches

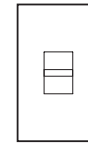

Switch

#### Slide-to-Off Fan-Speed Controls

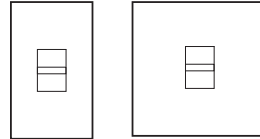

(Small Control)    (Large Control)

#### Receptacles/Plugs

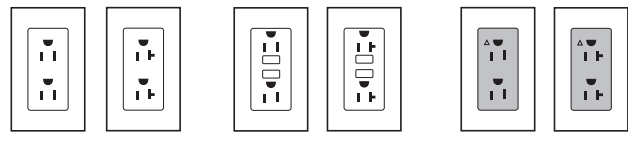

15A    20A    15A    20A    15A    20A  
Receptacles    GFCI Receptacles    Isolated Ground Receptacles

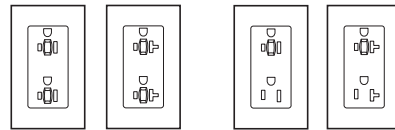

15A    20A    15A    20A  
Duplex for Dimming Use    Half for Dimming Use

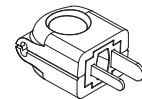

10A Replacement Plug for Dimming Use

#### Telephone/Cable TV Jacks/Ports

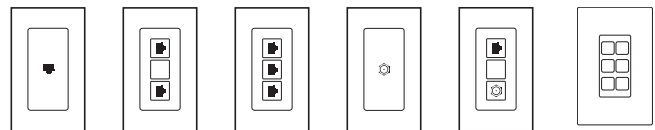

Single Telephone Jack    Double Telephone Jack    Triple Telephone Jack    Cable TV Jack    Telephone / Cable TV Jack    6-Port Frame Jack

#### Standard Multigang Wallplates

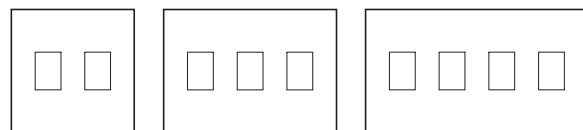

2-gang, 3-gang and 4-gang for dimmers/switches

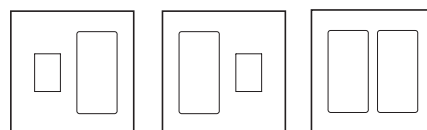

2-gang for a dimmer or switch and a receptacle or jack

Description	Maximum Capacity <sup>1</sup>	Model #
-------------	-------------------------------	---------

## DIMMERS



### Incandescent

#### Slide-to-Off Dimmers



#### SMALL CONTROL

Single pole	600W	NT-600-
Single pole	1000W	NT-1000-



#### LARGE CONTROL

Single pole	1500W	NT-1500-
Single pole	1950W	NT-2000-

Note: The NT-2000- does not have side sections that are removable and must be ganged with no fins removed.

#### Preset Dimmers



#### SMALL CONTROL

Single pole/3-way	600W	NT-603P-
Single pole/3-way	1000W	NT-1003P-



#### LARGE CONTROL

Single pole/3-way	1500W	NT-1503P-
-------------------	-------	-----------

Note: For 3-way and 4-way switching use NT-3PS- and NT-4PS- or other mechanical switches.

#### Omnislide™ Two-location Dimmers



For two-location dimming, use one Base Unit (NTB-600-, NTB-1000-) with one Auxiliary Unit (NTA-2-)

Base Unit	600W	NTB-600-
Base Unit	1000W	NTB-1000-

Auxiliary Unit (Use with Base Unit) <sup>2</sup> NTA-2-



### Electronic Low Voltage

#### Slide-to-Off Dimmers <sup>4</sup>



#### SMALL CONTROL

Single pole	300W <sup>3</sup>	NTELV-300-
Single pole	600W <sup>3</sup>	NTELV-600-

Note: Requires neutral wire connection. For electronic low voltage loads up to 1000W, use Nova T<sup>☆</sup> fluorescent dimmers (NTF-10- or NTF-103P-) with an ELVI-1000 interface.

<sup>1</sup> For capacities in multigang installations see derating.

<sup>2</sup> No derating required if ganged.

<sup>3</sup> Actual lamp wattage.

<sup>4</sup> Requires neutral wire connection.

<sup>5</sup> To determine the number of ballasts that can be controlled by Nova T<sup>☆</sup> fluorescent dimmer, divide the control capacity by the ballast current. For a complete list of Lutron ballasts and ballast currents, see the Fluorescent Dimming System Selection Guide (366-002).

Description	Maximum Capacity <sup>1</sup>	Model #
-------------	-------------------------------	---------

## DIMMERS



### Magnetic Low Voltage

#### Slide-to-Off Dimmers



#### SMALL CONTROL

Single pole, 120V	600VA (450W <sup>3</sup> )	NTLV-600-
Single pole, 277V <sup>4</sup>	600VA (450W <sup>3</sup> )	NTLV-600-277-
Single pole, 120V	1000VA (800W <sup>3</sup> )	NTLV-1000-
Single pole, 277V <sup>4</sup>	1000VA (800W <sup>3</sup> )	NTLV-1000-277-



#### LARGE CONTROL

Single pole	1500VA (1200W <sup>3</sup> )	NTLV-1500-
-------------	------------------------------	------------

#### Preset Dimmers



#### SMALL CONTROL

Single pole/3-way	600VA (450W <sup>3</sup> )	NTLV-603P-
Single pole/3-way	1000VA (800W <sup>3</sup> )	NTLV-1003P-



#### LARGE CONTROL

Single pole/3-way	1500VA (1200W <sup>3</sup> )	NTLV-1503P-
-------------------	------------------------------	-------------

For 3-way and 4-way switching use NT-3PS- and NT-4PS- or other mechanical switches.



### Fluorescent Dimming with Hi-lume® and Eco-10™ (ECO-Series) Electronic Ballasts

#### Slide-to-Off Dimmers <sup>2,5</sup>



#### SMALL CONTROL

Single pole, 120V	16A	NTF-10-
Single pole, 277V	8A	NTF-10-277-

Note: Use with Lutron Hi-lume or Eco-10 (ECO-Series) line voltage control Electronic Dimming Ballasts only.

#### Preset Dimmers <sup>2,5</sup>



#### SMALL CONTROL

Single pole/3-way, 120V	8A	NTF-103P-
Single pole/3-way, 277V	6A	NTF-103P-277-

Note: Use with Lutron Hi-lume or Eco-10 (ECO-Series) line voltage control Electronic Dimming Ballasts only. For 3-way and 4-way switching use NT-3PS- and NT-4PS- or other mechanical switches.



### Fluorescent Dimming with Eco-10 (TVE-Series) 0-10VDC Electronic Ballasts

#### Slide-to-Off Dimmers <sup>2</sup>



#### SMALL CONTROL

Single pole, 0-10VDC	60 ballasts/16A	NTFTV-
----------------------	-----------------	--------



Use with PP-20.  
Note: Use with Lutron Eco-10 (TVE-Series) 0-10VDC Electronic Dimming Ballasts only. Requires use of an external relay to switch ballast power on/off, Lutron model number PP-20.



### Fluorescent Dimming with Tu-Wire™ Electronic Ballasts

#### Slide-to-Off Dimmers



#### SMALL CONTROL

Single pole, 120V	5A	NTFTU-5A-
-------------------	----	-----------

Note: Use with Lutron Tu-Wire line voltage control Electronic Dimming Ballasts only.

Description	Maximum Capacity <sup>1</sup>	Model #
-------------	-------------------------------	---------

## HI-POWER 2•4•6™ DIMMING MODULES

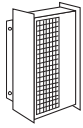

To increase load capacity up to 30,000W/VA in most popular sources, use one NT-600- or NT-603P- and add up to five dimming modules. Cannot be used with 0-10VDC ballast.

## LINEAR-SLIDE SWITCHES

### General Purpose Switching of All Sources and Motor Loads



*Linear-Slide Switches* <sup>2</sup>

#### SMALL CONTROL

Single pole, 120/277V	20A	NT-1PS-
3-way, 120/277V	20A	NT-3PS-
4-way, 120/277V	20A	NT-4PS-

### Switching for Motorized Shades

*Double pole, double throw switches for raise/lower/center off applications*



*Linear-Slide Switches* <sup>2</sup>

#### SMALL CONTROL

Momentary	2HP	NT-DPDT-CO-MO-120/240VAC
Maintain	1/2HP@120VAC; 2HP@240VAC	NT-DPDT-CO-MA-120/240VAC

Note: To control more than one motor, consult Lutron Technical Support.

## FAN-SPEED CONTROLS



### Quiet Controls



For use with one ceiling paddle fan.  
*Slide-to-Off Fan-Speed Control* <sup>2</sup>

#### SMALL CONTROL

Single pole, 3-speed	1.5A	NTFSQ-
----------------------	------	--------



### Fully Variable Controls

For use with one or more ceiling, ventilation, or exhaust fan. Do not mix fan types on one control.

*Slide-to-Off Fan-Speed Control*



#### SMALL CONTROL

Single pole/Adjustable Minimum Speed	6A	NTFS-6E-
--------------------------------------	----	----------



#### LARGE CONTROL

Single pole/Adjustable Minimum Speed	12A	NTFS-12E-
--------------------------------------	-----	-----------

1 For capacities in multigang installations see derating information.

2 No derating required if ganged.

3 Actual lamp wattage.

4 Requires neutral.

5 A physical barrier (partition) must exist when ganging with line-voltage products.

Description	Maximum Capacity <sup>1</sup>	Model #
-------------	-------------------------------	---------

## ACCESSORIES

### Receptacles

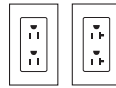

*Receptacle* <sup>2</sup>

15A, 125V NTR-15-20A, 125V NTR-20-
------------------------------------

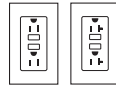

*GFCI Receptacle* <sup>2</sup>

15A, 125V NTR-15-GFCI-20A, 125V NTR-20-GFCI-
--

Note: The insert is permanently attached.

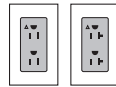

*Isolated Ground Receptacle* <sup>2</sup>

15A, 125V NTR-15-IG-OR-20A, 125V NTR-20-IG-OR-
--

Note: Receptacle is orange; wallplate is color selected.

Receptacles can be special ordered to match wallplate color; consult Customer Service.

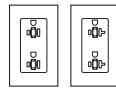

*Duplex for Dimming Use* <sup>2</sup>

15A, 125V NTR-15-DFDU-20A, 125V NTR-20-DFDU-
--

Note: The insert is permanently attached.

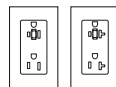

*Half for Dimming Use* <sup>2</sup>

15A, 125V NTR-15-HFDU-20A, 125V NTR-20-HFDU-
--

Note: The insert is permanently attached.

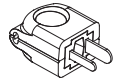

*Replacement Plug for Dimming Use*

10A, 125V RP-FDU-10-
----------------------

### Telephone and Cable Television Jacks



*Cable TV Jack* <sup>2,5</sup>

#### SINGLE

F-STYLE	NT-CJ-
---------	--------

75-Ohm, coaxial cable jack



*Telephone Jack* <sup>5</sup>

#### SINGLE

6-conductor, RJ11	NT-PJ-
-------------------	--------

Note: Also accepts most 4-conductor plugs.



#### DOUBLE

8-conductor, RJ45, Category 5	NT-PJ8X2-
-------------------------------	-----------

Note: Also accepts most 4- or 6-conductor plugs.



#### TRIPLE

8-conductor, RJ45, Category 5	NT-PJ8X3-
-------------------------------	-----------

Note: Also accepts most 4- or 6-conductor plugs.



*Telephone/Cable Jack* <sup>2,5</sup>

8-conductor, RJ45, Category 5 phone jack-F-style, 75-Ohm, coaxial cable jack

NT-PJ8CJ-
-----------

Note: Phone jack also accepts most 4- or 6- conductor plugs.

Wallplate and insert match specified color. Device (e.g., Jack) and device trim are white for ivory, white and beige products; black for gray, brown, black, metal, special metal and anodized aluminum products.

Description	Rating	Model #
-------------	--------	---------

**ACCESSORIES**

**Field Customizable Multi-Port Frame**

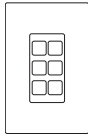







6-Port Frame	Shipped with 6 blanks <i>Shown with blanks</i>	NT-6PF- <input type="checkbox"/>
--------------	---	----------------------------------

Product above: For use with Lutron connectors shown below. Also compatible with Hubble Xcelerator™ and snap-fit connectors.

**Connectors**

*For use with 6-port frame (NT-6PF-). Each connector fills one port.*

	Phone Jack	6-conductor, RJ11, Category 3	CON-1P-C3-WH
	Phone Jack	8-conductor, RJ45, Category 5e	CON-1P-C5E-WH
	Phone Jack	8-conductor, RJ45, Category 6	CON-1P-C6-WH
	Fiber Jack	MT-RJ Feed-Through	CON-1F-MTRJ-WH
	Fiber Jack	SC Simplex	CON-1F-SC-WH
	Fiber Jack	LC Non-Flush Mount	CON-1F-LC-WH
	Fiber Jack	ST Style	CON-1F-ST-WH
	Cable Jack	F-Style, 75-Ohm Coaxial cable	CON-1C-WH
	BNC Jack	BNC connector	CON-1B-WH

Connectors available in white (WH) only. For information about additional colors contact Lutron Customer Service.

Description	Model #
-------------	---------

## STANDARD MULTIGANG WALLPLATES



Single-gang wallplate is provided with Nova T<sup>☆</sup> product.

### 2-Gang



**FOR TWO DIMMERS OR SWITCHES**  
4.56"W (116mm) x 4.56"H (116mm) VWP-2-



**FOR TWO RECEPTACLES OR JACKS**  
4.56"W (116mm) x 4.56"H (116mm) VWP-2R-



**FOR ONE DIMMER OR SWITCH AND ONE RECEPTACLE OR JACK**  
4.56"W (116mm) x 4.56"H (116mm) VWP-2CR-



**FOR ONE RECEPTACLE OR JACK AND ONE DIMMER OR SWITCH**  
4.56"W (116mm) x 4.56"H (116mm) VWP-2RC-

### 3-Gang

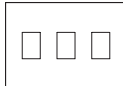

**FOR THREE DIMMERS OR SWITCHES**  
6.32"W (161mm) x 4.56"H (116mm) VWP-3-



**4-Gang**  
**FOR FOUR DIMMERS OR SWITCHES**  
8.45"W (215mm) x 4.56"H (116mm) VWP-4-

## STANDARD COLORS/FINISHES

### Matte Finishes (Ships in 3-5 days)

Add color/finish suffix to model number to order. Example: NT-600-**WH**  
 WH White      BE Beige      IV Ivory      AL Almond  
 LA Light Almond      GR Gray      TP Taupe      SI Sienna  
 BR Brown      BL Black

## SPECIAL ORDER MULTIGANG AND METAL WALLPLATES

When ordering product for use with metal wallplates, the product and wallplate must be ordered separately. See the Nova T<sup>☆</sup>/Nova Wallplate Ordering Guide in the Lutron Residential Lighting Controls Catalog (360-975) for ordering procedure. See below for complete list of metal finishes.

### Metal Finishes (Ships in 4-6 weeks)

SB Satin Brass      BB Bright Brass      BC Bright Chrome

### Special Metal Finishes

QB Antique Brass      QZ Antique Bronze      SC Satin Chrome  
 SN Satin Nickel      BN Bright Nickel

### Anodized Aluminum Finishes

CLA Clear      BLA Black      BRA Brass

## CUSTOM COLOR MATCHING

Custom color matching is available for all Nova T<sup>☆</sup> products. A swatch or sample is all that is required. Call customer service to arrange for a color-matched control.

## ENGRAVED CONTROLS AND WALLPLATES

Engraving is available for all Nova T<sup>☆</sup> products. Engraving schedules are available in the Lutron Residential Lighting Controls Catalog (360-975) or through Customer Service 888-588-7661.

## DERATING/MAXIMUM CAPACITY

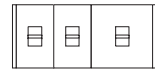

No side sections removed  
**(Full Capacity)**

One side section removed  
**(End Units)**

Two side sections removed  
**(Middle Unit)**

### Incandescent Dimmers

600W	500W	300W
1000W	900W	700W
1500W	1250W	1000W
1950W <sup>1</sup>	—	—

### Electronic Low Voltage

300W <sup>2</sup>	300W <sup>2</sup>	250W <sup>2</sup>
600W <sup>2</sup>	500W <sup>2</sup>	400W <sup>2</sup>

### Magnetic Low Voltage

600VA (450W <sup>2</sup> )	500VA (400W <sup>2</sup> )	300VA (250W <sup>2</sup> )
1000VA (800W <sup>2</sup> )	900VA (750W <sup>2</sup> )	700VA (500W <sup>2</sup> )
1500VA (1200W <sup>2</sup> )	1250VA (1000W <sup>2</sup> )	1000VA (800W <sup>2</sup> )

### Fluorescent Hi-lume/Eco-10

6A	No Derating Required
8A	No Derating Required
16A	No Derating Required

### Fluorescent Tu-Wire

5A	4A	3.3A
----	----	------

### Fluorescent Dimming with Eco-10 (TVE-Series) 0-10VDC Electronic Ballasts

60 ballasts / 16A	No Derating Required
-------------------	----------------------

### Quiet Fan-Speed Controls

1.5A	No Derating Required
------	----------------------

### Fully Variable Fan-Speed Controls

6A	4.2A	2.5A
12A	10A	8.3A

<sup>1</sup> Control must be ganged without removing side sections. The NT-2000- does not have side sections that are removable.

<sup>2</sup> Actual lamp wattage.

## WIRING DIAGRAMS

**Wiring Diagram 1**  
Single-Pole Wiring

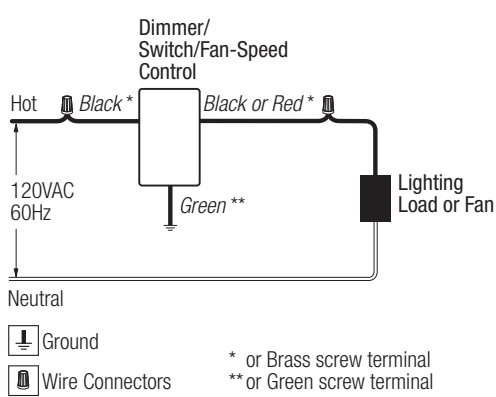

**Model #**

NT-1PS-  
NT-600-  
NT-1000-  
NT-1500-  
NT-2000-  
NTFSQ-  
NTFTU-5A-  
NTLV-600-  
NTLV-1000-  
NTLV-1500-

**Wiring Diagram 4**  
Single-Pole Wiring, Fan Only

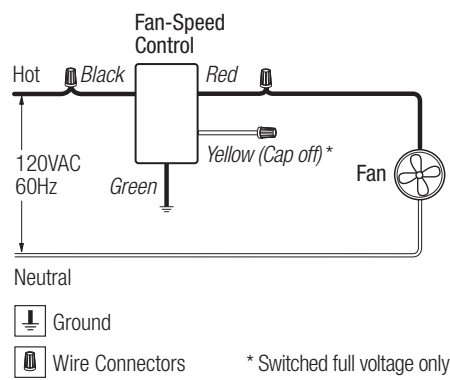

**Model #**

NTFS-6E-  
NTFS-12E-

**Wiring Diagram 2**  
Single-Pole Wiring of 3-Way Control

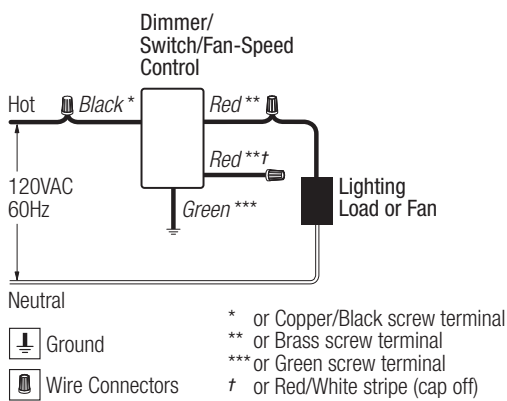

**Model #**

NT-3PS-  
NT-603P-  
NT-1003P-  
NT-1503P-  
NTLV-603P-  
NTLV-1003P-  
NTLV-1503P-

**Wiring Diagram 5**  
Single-Pole using Fan/Light

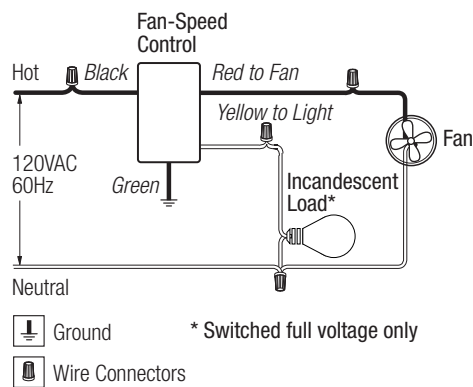

**Model #**

NTFS-6E-  
NTFS-12E-

**Wiring Diagram 3**  
Single-Pole Wiring

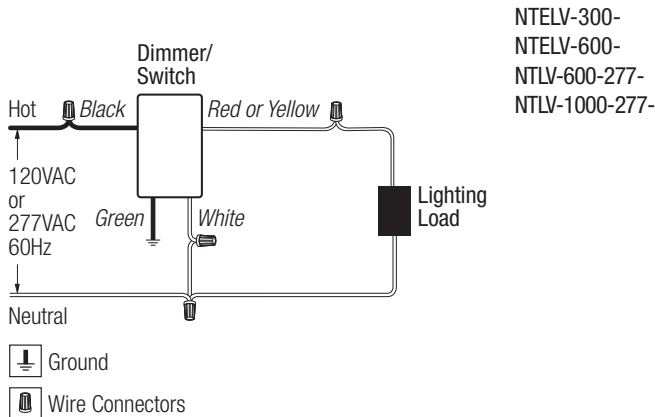

**Model #**

NTELV-300-  
NTELV-600-  
NTLV-600-277-  
NTLV-1000-277-

**WIRING DIAGRAMS**

**Wiring Diagram 6  
Two Location Wiring**

**Model #**

**Base Control  
Line Side**

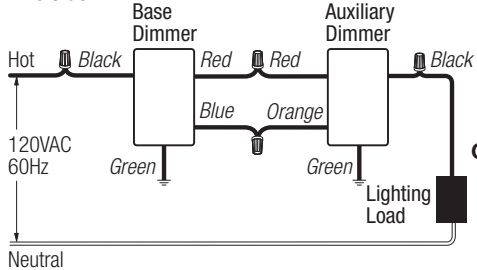

**Base Control  
Load Side**

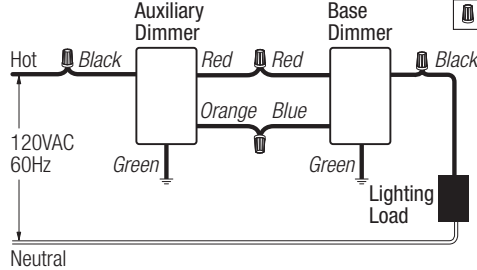

- Ground
- Wire Connectors

NTA-2-  
NTB-600-  
NTB-1000-

**Wiring Diagram 7  
3-Way Wiring**

**Model #**

**Control  
Line Side**

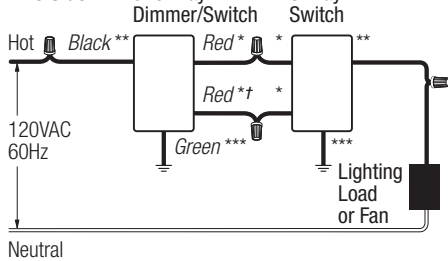

**Control  
Load Side**

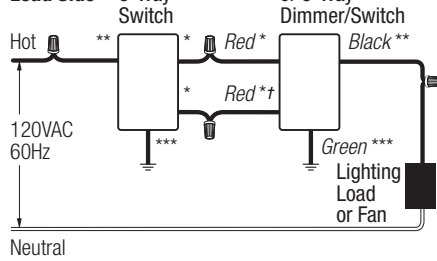

- Ground
- Wire Connectors
- \* or Brass/Gold screw terminal or Copper/Black screw terminal
- \*\* or Green screw terminal
- † or Red/White stripe

NT-3PS-  
NT-603P-  
NT-1003P-  
NT-1503P-  
NTLV-603P-  
NTLV-1003P-  
NTLV-1503P-

**Wiring Diagram 8  
4-Way Wiring**

**Model #**

**Control  
Line Side**

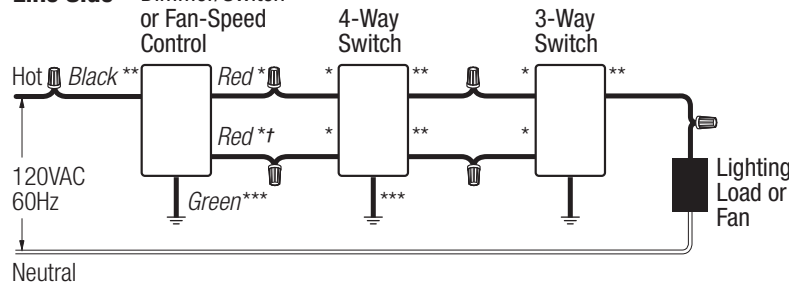

- Ground
- Wire Connectors
- \* or Copper/Black screw terminal
- \*\* or Brass/Gold screw terminal
- \*\*\* or Green screw terminal
- † or Red/White stripe

NT-3PS-  
NT-4PS-  
NT-603P-  
NT-1003P-  
NT-1503P-  
NTLV-603P-  
NTLV-1003P-  
NTLV-1503P-

**Control  
Load Side**

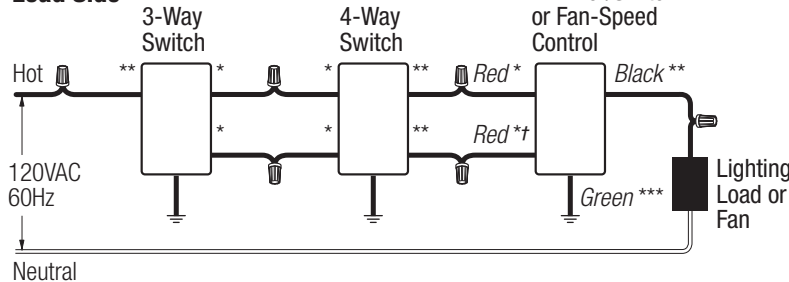

## WIRING DIAGRAMS

### Wiring Diagram 9 Cable TV Jack Wiring

**Model #**

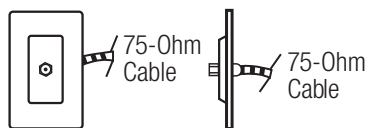

Cable TV Jack

NT-CJ-

### Wiring Diagram 10 Telephone Jack Wiring

**Model #**

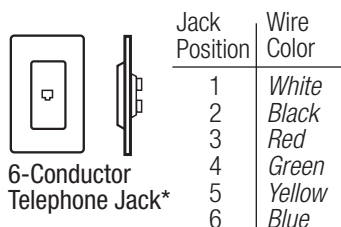

6-Conductor Telephone Jack\*

NT-PJ-

\*accepts most 4-conductor jacks

### Wiring Diagram 11 Telephone Jack Wiring

**Model #**

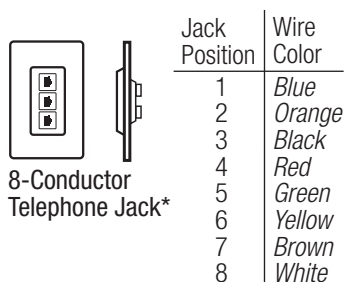

8-Conductor Telephone Jack\*

NT-PJ8CJ-  
NT-PJ8X2-  
NT-PJ8X3-

\*accepts most 4- or 6-conductor jacks.

### Wiring Diagram 12 Receptacle Wiring

**Model #**

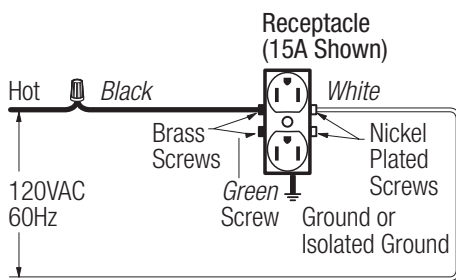

Neutral

NTR-15-  
NTR-15-IG-OR-  
NTR-20-  
NTR-20-IG-OR-

⚡ Building Ground (To Metal Box)

⚡ Ground

🔌 Wire Connectors

### Wiring Diagram 13 GFCI Receptacle Wiring

**Model #**

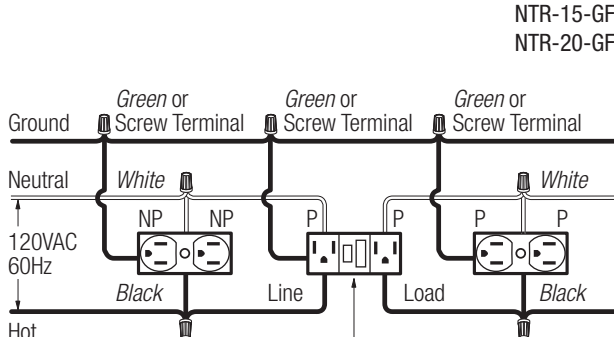

GFCI Receptacle (15A Shown)

P-Protected  
NP-Not Protected

🔌 Wire Connectors

NTR-15-GFCI-  
NTR-20-GFCI-

### Wiring Diagram 14 DFDU Receptacle Wiring

**Model #**

NTR-15-DFDU-  
NTR-20-DFDU-

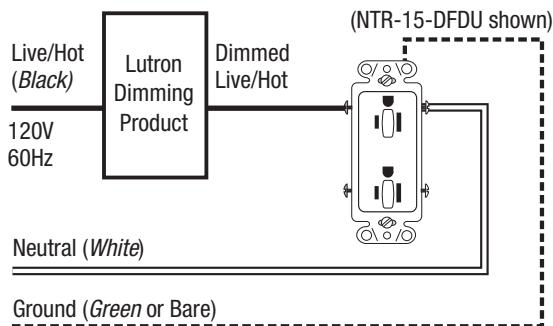

Neutral (White)

Ground (Green or Bare)

### Wiring Diagram 15 HFDDU Receptacle Wiring

**Model #**

NTR-15-HFDDU-  
NTR-20-HFDDU-

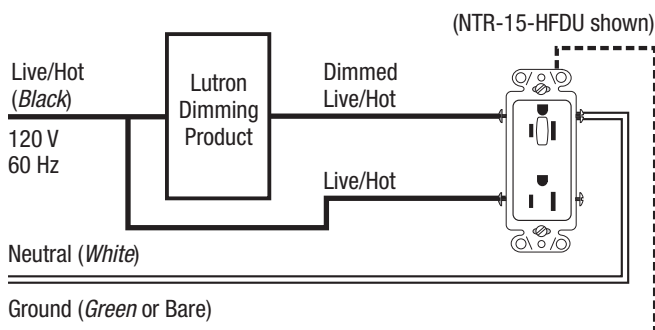

Neutral (White)

Ground (Green or Bare)

**WIRING DIAGRAMS**

**Wiring Diagram 16**  
**Single-Pole Wiring**

**Model #**

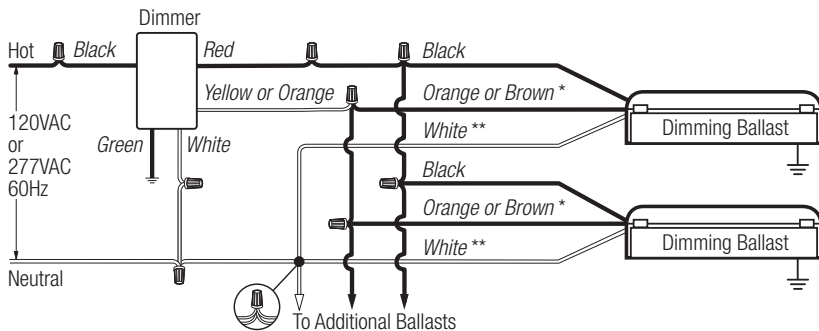

- Ground
- Wire Connectors
- Typical 4-Wire Connection

NTF-10-  
NTF-10-277-

\* or Yellow/Blue or Yellow/Green when used with magnetic dimming ballasts  
\*\* must use lamp disconnect sockets with magnetic dimming ballasts

**Wiring Diagram 17**  
**Single-Pole Wiring of a 3-Way Control**

**Model #**

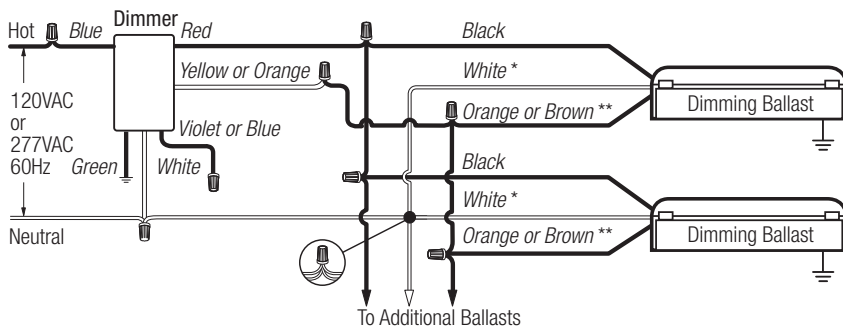

- Ground
- Wire Connectors
- Typical 4-Wire Connection

NTF-103P-  
NTF-103P-277-

\* must use lamp disconnect sockets with magnetic dimming ballasts  
\*\* or Yellow/Blue or Yellow/Green when used with magnetic dimming ballasts

**Wiring Diagram 18**  
**3-Way Wiring**

**Model #**

**Control Load Side**

NTF-103P-  
NTF-103P-277-

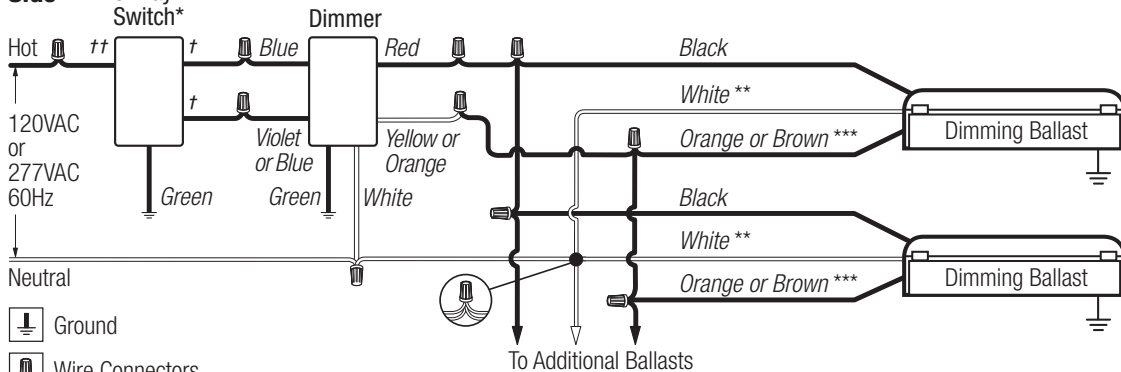

- Ground
- Wire Connectors
- Typical 4-Wire Connection

\* 3-Way switch must be wired on line side of dimmer  
\*\* must use lamp disconnect sockets with magnetic dimming ballasts  
\*\*\* or Yellow/Blue or Yellow/Green when used with magnetic dimming ballasts  
t or Copper/Black screw terminal  
tt or Brass/Gold screw terminal

**WIRING DIAGRAMS**

**Wiring Diagram 19  
Dimming with ON/OFF Control Using PP-20 Relay**

**Model #**

NTFTV-

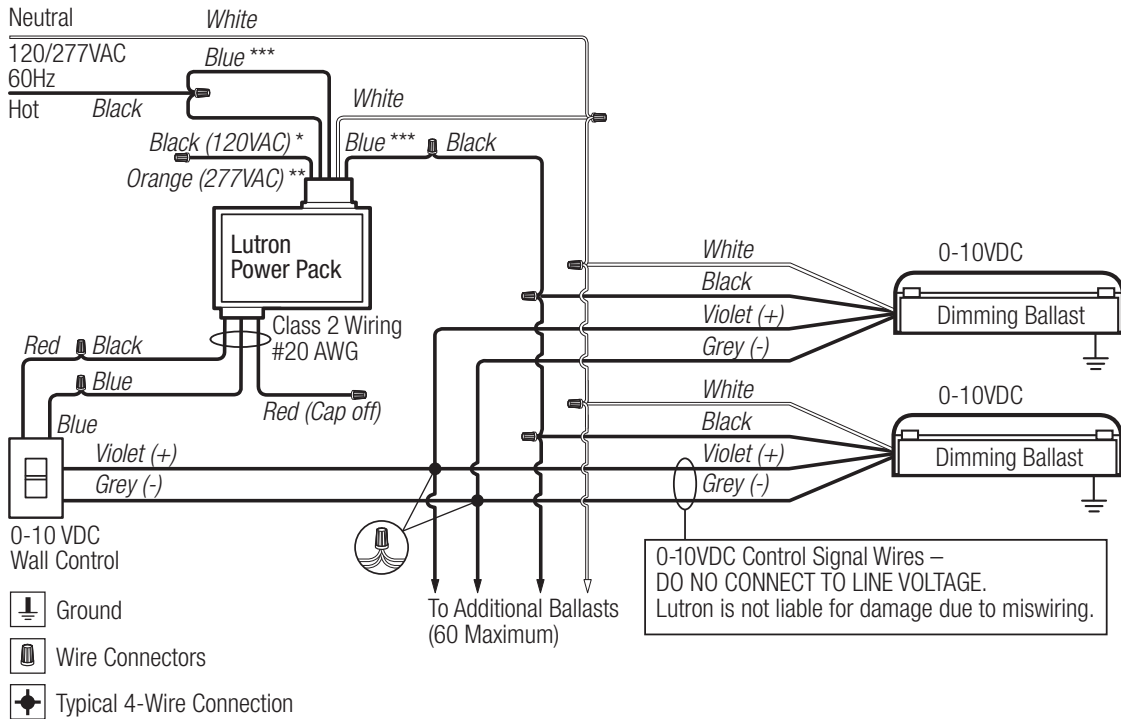

\* 120VAC wiring shown: cap off Orange wire as shown  
 \*\* 277VAC wiring: cap off Black wire and connect Blue and Orange to Hot  
 \*\*\* Blue wires are interchangeable-either may be connected to line side or load side

**NOVA T<sup>☆</sup> CONTROLS AND ACCESSORIES**

**PART 1 – GENERAL**

**1.01 SUMMARY**

- A. Scope: Provide, install and test all switches, dimmers and related devices as specified herein for the areas indicated on the drawings, specifications, and load schedules.
- B. Related Sections: Section 16580 (Ballasts), Section 16570 (Dimming Systems).

**1.02 REFERENCES**

- A. UL 20, UL 1472, CSA, NOM, ISO 9001

**1.03 SYSTEM DESCRIPTION AND OPERATION**

- A. Permanently installed, wallbox mounted switches and dimmers
- B. Permanently installed, wallbox mounted fan-speed controls
- C. Permanently installed, wallbox mounted receptacles
- D. Permanently installed, wallbox mounted data, voice and cable jacks
- E. Screwless, seamless wallplates

**1.04 SUBMITTALS**

- A. Submit manufacturer's standard catalog data giving all application, wiring, and installation information on basic components and wallplate kits. Provide test data and/or samples as required to demonstrate conformance with PART 2 of this specification.

**1.05 QUALITY ASSURANCE**

- A. Manufacturer shall have a minimum of 10 years continuous experience in manufacturing wallbox dimming products.
- B. Dimmers, switches and Fan-speed controls shall be UL listed, CSA and NOM approved specifically for each required load (i.e., tungsten, electronic low voltage transformer, magnetic low voltage transformer, and fluorescent). Manufacturer shall provide file card or certificate upon request. Universal load-type dimmers shall not be acceptable.
- C. Manufacturer shall maintain ISO 9001 certification and provide a copy of the certificate upon request.

**1.06 WARRANTY**

- A. All devices shall be covered by a minimum one-year warranty.

**PART 2 – EQUIPMENT**

**2.01 ACCEPTABLE MANUFACTURERS**

- A. Lutron Electronics Co., Inc.
- B. Unless otherwise noted, all basic components (dimmer, fan-speed control, switch, receptacle, telephone jack and cable TV jack) and wallplate kits shall be provided by one manufacturer.

**2.02 EQUIPMENT**

- A. Controls Lutron Nova T<sup>☆</sup> Style
  - 1. Performance
    - a. Dimmers shall provide full-range, continuously variable control of light intensity.
    - b. Controls shall fit a 1 inch wide, 1.5 inch tall wallplate opening with a vertical linear-slide. Controls shall be thin profile with no exposed heatsink/yoke. Unless otherwise specified, controls shall have a matte finish.

- c. Controls shall provide a vertical slider allowing the light level or fan speed to be set by the user. "Slide-to-off" controls shall use the vertical slider to turn the control on and off. "Preset" dimmers shall provide the on/off function independent of the dimmer slider position. This preset function shall be provided as a push on/push off switch integral to the slider knob and visibly distinct from the slider. For preset dimmers, when the lights are on, the slider shall change the light level and when the lights are off, the slider shall preselect the light level the lights will turn on to.
- d. Control on/off function must be accomplished utilizing a mechanical air-gap switch to totally disconnect power from the load during "off" condition, no leakage current shall be present at the fixture(s).
- e. Slider shall be captured behind wallplate.
- f. Preset dimmers shall be capable of multi-location on and mechanical air-gap off using standard 3-way and 4-way switches. Multi-location switches shall be Nova T<sup>☆</sup> style.
- g. Controls shall be able to have their visible plastic parts replaced, for color changes in the field, without removing the body of the control from the wall and without requiring special tools.
- h. Within rated capacity, dimmers shall be available for direct control of incandescent, electronic low voltage, magnetic low voltage, and fluorescent. Matching fan-speed controls and switches shall also be available.
- i. Controls shall be capable of operating at the rated capacity; this includes modified capacities for ganging configurations which require the removal of fins. Operation at rated capacity shall be possible across the full ambient temperature range, without shortening design lifetime.
- j. To ensure a precise color match between all plastic parts, color variation of any matte finish control shall not exceed a delta E of 1, CIE L\*a\*b\* color units, as defined in ASTM E 308-99.
- k. Dimmer shall provide smooth and continuous Square Law dimming curve, for the full slider travel, on their rated load per The IESNA Lighting Handbook, 9th edition, p. 27-4.
- l. Controls shall meet the applicable requirements of UL 20 and UL 1472 referring to the inclusion of a visible, accessible air-gap off switch and the limited short circuit test.
- m. Controls shall meet ANSI/IEEE Std. C62.41-1980, tested to withstand voltage surges of up to 6000V and current surges of up to 200A without damage.
- n. Dimmers shall be designed to reduce interference with radio, audio, and video equipment.
- o. Controls shall incorporate power-failure memory. Should power be interrupted and subsequently returned, the lights or fans will come back on to the same levels set prior to the power interruption. Restoration to some other default level is not acceptable.
- p. Controls shall not be susceptible to damage or loss of memory due to static discharge.
- q. Dimmer shall include voltage compensation to compensate light output for variation in the AC line-voltage. Dimmers in which the light output is not held constant with varying AC line-voltage shall not be acceptable.
- r. Controls shall operate in an ambient temperature range of 0°C (32°F) to 40°C (104°F).

- s. 3-Way controls shall wire using conventional 3-way and 4-way wire runs.
  - t. Contractors shall install all backboxes with a minimum wallbox depth of 2.5 inches.
2. Incandescent Dimmers
    - a. Provide incandescent dimmers for direct control of up to a full 20A lighting circuit, which is derated by 20% to 16 Amps per the NEC.
    - b. Dimmers shall have a high-end of no less than 95% of line voltage.
    - c. Dimmer shall be capable of operating in either 3-way switch location.
  3. Electronic (Solid-State) Low Voltage (ELV) Transformer Dimmers
    - a. Dimmers shall contain circuitry specifically designed to control the input of electronic (solid state) low voltage transformers. Dimmers using standard phase control shall not be acceptable.
    - b. Provide ELV dimmers for direct control of up to 600 watts of electronic low voltage load.
    - c. Dimmers shall have a resettable overload protection that automatically shuts off when dimmer capacity is exceeded. Protection methods that are non-resettable or require the device to be removed from the wall to reset shall not be acceptable.
    - d. Dimmers shall be designed to withstand a short, per UL 1472 section 5.10, between load hot and either neutral or ground without damage to the dimmer.
    - e. Dimmers shall have a high-end of no less than 90% of line voltage.
  4. Magnetic Low Voltage (MLV) Transformer Dimmers
    - a. Provide MLV dimmers for direct control of up to 1500VA of 120 volt magnetic low voltage load.
    - b. Provide MLV dimmers for direct control of up to 1000VA of 277 volt magnetic low voltage load.
    - c. Dimmers shall contain circuitry specifically designed to control and provide a symmetrical AC waveform to the input of magnetic low voltage transformers per UL1472 section 5.11.
    - d. Dimmers shall not cause a magnetic low voltage transformer to operate above the transformers rated operating current or temperature.
    - e. Dimmers shall have a high-end of no less than 95% of line voltage.
    - f. Dimmer shall be capable of operating in either 3-way switch location.
  5. Fluorescent Dimming Ballast Dimmers
    - a. Provide Fluorescent dimmers for direct control of fluorescent dimming ballasts up to the manufacturers specified rating.
    - b. Dimmers shall be designed to operate the following ballasts. Dimmers and ballasts shall be produced by the same manufacturer to ensure proper ballast/control compatibility:
      - 1) Hi-Lume<sup>®</sup> Architectural Dimming Ballasts (1% 3-wire)
      - 2) Hi-Lume<sup>®</sup> Compact<sup>™</sup> Lamp Dimming Ballasts (5% 3-wire)
      - 3) Eco-10<sup>™</sup> Lighting Management Dimming Ballasts (10% 3-wire)
      - 4) Eco-10<sup>™</sup> Lighting Management Dimming Ballasts (10% 0-10VDC)
      - 5) Tu-Wire<sup>™</sup> High Performance Dimming Ballasts (5% 2-wire)
    - c. Dimmers shall be designed to provide full ballast output at high-end.
  6. Remote dimming modules for high power loads
    - a. Where lighting loads exceed the full rated capacity of single dimmers, provide a Nova T<sup>☆</sup> incandescent dimmer driving high power modules. High power module and dimmer shall be from the same manufacturer to ensure compatibility.
    - b. High power modules shall be remotely mounted.
    - c. High power module shall be rated and UL listed for control of incandescent, magnetic low voltage, electronic low voltage, fluorescent, and neon/cold cathode loads in increments of 2,000 Watts up to 30,000 Watts.
  7. Fan-Speed Controls:
    - a. Fan-speed controls shall be UL Listed, CSA and NOM approved, Lutron Nova T<sup>☆</sup> style.
    - b. Quiet fan-speed model shall provide three speed settings with slide-to-off function.
    - c. Quiet fan-speed control shall provide single-pole control of one paddle fan (1.5A max.).
    - d. Fully variable model shall provide fully variable fan-speed control with slide-to-off function.
    - e. Fully variable model shall provide single pole control of multiple paddle fans, ventilation or exhaust fans (12A max.).
  8. Switches:
    - a. Switches shall provide on/off control of any 120/277 VAC load up to 20A. Switches shall be UL Listed as general-use AC switches, Lutron Nova T<sup>☆</sup> style.
    - b. Switches shall be available in single-pole, 3-way and 4-way configurations.
- B. Accessories Lutron Nova T<sup>☆</sup> Style
1. Receptacle Components Lutron Nova T<sup>☆</sup> Style
    - a. All receptacles shall be UL Listed, CSA and NOM approved.
    - b. Receptacles shall be two pole, three wire ground and rated for 15A or 20A as specified at 125 VAC. All receptacles shall be NEMA configuration type 5-15R or 5-20R.
    - c. Isolated Ground Receptacles shall be Lutron Nova T<sup>☆</sup> style with two pole, three-wire ground and rated 15A or 20A as specified at 125VAC. Configuration shall be of the duplex type with rectangular NEMA WD-6 design. Receptacle face shall be orange with black isolated ground triangle or standard Nova T<sup>☆</sup> colors with orange isolated ground triangle.
    - d. Ground-fault interrupter receptacles shall be Lutron Nova T<sup>☆</sup> style with two-pole, three-wire ground and rated 15A or 20A at 125VAC. Configuration shall be of the duplex type with rectangular NEMA WD-6 design. Receptacles shall have a 5 milliampere ground-fault trip level with "test" and "reset" buttons.
    - e. Receptacles for dimming use shall be Lutron Nova T<sup>☆</sup> style with two pole, three-wire ground and rated 15A or 20A at 125VAC. Designed to reject standard NEMA plugs and accept only the special mating Lutron replacement plug.
  2. Telephone Jack and Cable TV Jack Components Lutron Nova T<sup>☆</sup> Style
    - a. Contractor shall provide an appropriate barrier (partition) to isolate jack from high-voltage wiring when ganged with a dimmer, fan-speed control, switch, or receptacle. This complies with NEC Articles 800-3 and 820-13.
    - b. Telephone jacks shall be designed to mate with standard 4- or 6-conductor modular jacks, and be compatible with 2, 4 or 6 conductor lines. Telephone jacks shall meet FCC Part 68, paragraph F standards to ensure compatibility with U.S. telephone systems.

- c. Eight-conductor telephone jacks shall be Category 5 Voice and Data rated. They shall be FCC Part 68, Sub-part F compliant.
  - d. Cable TV jacks shall be the coaxial type, designed for use with standard 75-Ohm cables.
  - e. Category 5 voice, data, or cable configurations shall be available in single gang, up to three functions per gang.
- C. Wallplates Lutron Nova T<sup>☆</sup> Style
- 1. Wallplates shall be manufactured from durable polycarbonate plastic with matte finish, and shall attach to the basic components without using exposed hardware or screws.
  - 2. Multigang wallplates shall provide a continuous, seamless cover for control and/or accessory combinations with no exposed hardware or screws. Custom wallplate configurations shall be available.
  - 3. Multigang wallplates shall include snap in auto-align adapter plate for proper device alignment and wallplate attachment.
  - 4. Control, accessory and wallplate profiles shall not exceed .30 inches from wall surface to faceplate front surface.
  - 5. To ensure a precise color match between all plastic parts, color variation of any gloss finish control or wallplate shall not exceed delta E of 1, CIE L\*a\*b\* color units, as defined in ASTM E 308-99.
  - 6. Visible parts of dimmers, switches, standard receptacles, cable jacks or any wallplate shall exhibit ultraviolet stability when tested with multiple actinic light sources as defined in ASTM D4674-89.

#### 2.03 SOURCE QUALITY CONTROL

- A. All dimming controls shall be 100% function tested at the time of manufacture. Statistical sampling plan shall not be acceptable.

## PART 3 – EXECUTION

---

#### 3.01 INSTALLATION

- A. Contractor shall furnish all devices (dimmers, accessories, & wallplate kits), labor and other services necessary for the proper installation of the devices as indicated on the drawings and specified herein.
- B. Contractor shall be responsible for derating dimmer capacity if side sections are removed.
- C. Contractor shall run separate neutral wires in 120/208 VAC installations.
- D. Devices shall be installed utilizing manufacturer's recommended application, wiring and installation instructions.
- E. Contractor to provide seamless wallplate covers per specification 2.02 for all devices ganged in a common box. Contractor shall provide barriers within the box where required by code.

#### 3.02 FIELD QUALITY CONTROL

- A. Twenty-four hours a day, seven days a week, global customer service and technical hotline available.
- B. Supplemental information shall be provided by manufacturers Internet site.