

Universal's AccuStart[®]5HB ballasts are designed specifically for the demanding high ambient applications where today's T5HO high lumen fluorescent systems are specified. Designed with high efficiency electronic technology and constructed for maximum thermal dissipation, these new ballasts can provide long reliable service in high temperature installations where HID systems are typically installed.

4-Lamp T5HO systems save 228 watts per fixture compared to standard 400 watt metal halide systems while improving the quality of light with long life fluorescent lamps. Since AccuStart[®]5HB ballasts use programmed start technology, they can be used with occupancy sensors or other switching systems for even greater energy savings. All 4-lamp AccuStart[®]5HB ballasts feature inboard/outboard switching leads that allow separate control of two lamps for greater application flexibility. Additionally, these ballasts feature installer-friendly universal input voltage to minimize field installation issues.

AccuStart[®]5HB's high efficiency technology transfers more power to the lamps and generates less heat in the ballast. Combining this technology with long life components and a construction that draws heat away from the electronic components and into the fixture, AccuStart[®]5HB ballasts are designed to perform reliably in the toughest applications. This new family of ballasts is designed and warranted for use in high ambient temperatures with a maximum case temperature of 90°C. For tough, high temperature conditions, AccuStart[®]5HB is the ballast.



Features and Benefits

Rugged HB construction

Maximizes heat transfer to the luminaire
Provides reliable operation in high ambient temperatures

High efficiency technology

Maximizes energy savings
Cooler ballast operation provides longer life

Wide ambient temperature range

Suitable for cold temperature applications
90°C maximum allowable case temperature

Universal input voltage: 120 – 277 volt operation

Minimizes ordering and installation confusion

Programmed start technology

Compatible with occupancy sensors
Maintains lamp life in frequently switched applications

Lamp switching control lead (4-Lamp)

Allows for inboard/outboard switching with a single ballast
4/2, 3/2, or 3/1 switching combinations

Low THD (<10%), High PF (>.98)

Meets stringent power quality specifications

End-of-lamp-life shutdown circuitry with auto re-strike

Provides safe operation when lamps fail
Ignites new lamps upon installation

Series / Parallel lamp operation (4-lamp)

Maintains light output when one lamp fails



APPLICATIONS:

Manufacturing sites
Warehousing
Retail installations
Industrial facilities



T5HO Electronic Ballasts for High Bay Installations

Performance Specifications

Part Number	F54T5HO Lamp Qty	Input Voltage	Power (Watts)	Input Current (Amps)	Ballast Factor	THD	Power Factor	Min Start Temp	Dim.	Wiring Diagram
B254PUNVHB-D	2	120	120	1.03	1.00	<10%	>0.98	-20°F/-29°C	D	1
	2	277	117	0.43	1.00					
B454PUNVHB-E	3	120	184	1.52	1.05	<10%	>0.98	-20°F/-29°C	E	3,4
	3	277	182	0.66	1.05					
B454PUNVHB-E	4	120	235	1.96	1.00	<10%	>0.98	-20°F/-29°C	E	2
	4	277	229	0.84	1.00					
B254PHRVHB-E	2	347	120	0.35	1.00	<10%	>0.98	-20°F/-29°C	E	1
	2	480	119	0.26	1.00					

Dimensions

Case Style	Mounting Length	Overall Length	Width	Height	Wiring Connection
D	16.28"	16.88"	1.18"	1.00"	w/ Connectors
E	16.28"	16.88"	1.74"	1.18"	w/ Leads

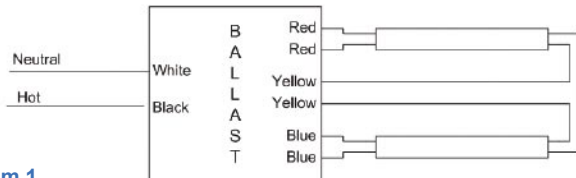

Diagram 1

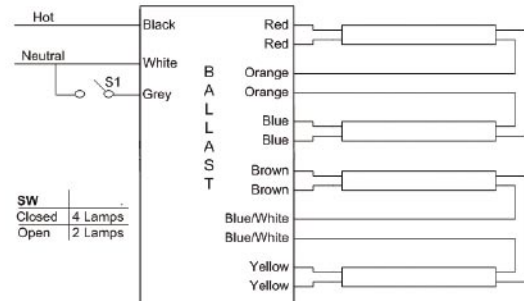

Diagram 2

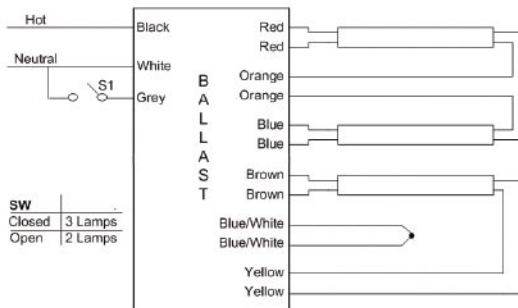

Diagram 3

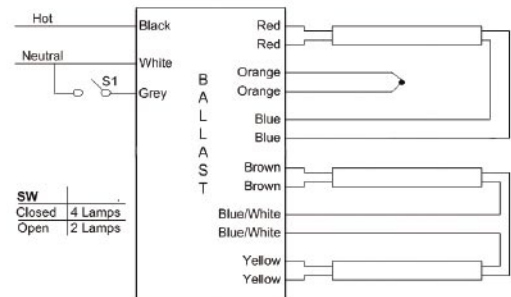

Diagram 4

It's Easy To Reach Us...

Phone: 615.316.5100
Fax: 615.316.5162
Website: www.universalballast.com
Email: webmaster@universalballast.com

A5HB0705

Universal Lighting Technologies, Inc. 26 Century Blvd., Suite 500 Nashville, TN 37214-3683



For Technical Engineering Services (TES), application support and warranty information, call 1.800.BALLAST. All specification information is subject to change without notification. © 2007 Universal Lighting Technologies, Inc.