

DIMENSIONS AND DATA

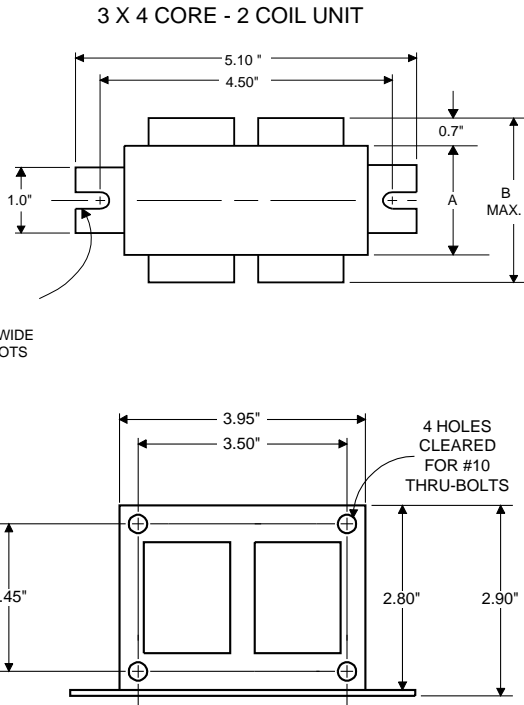

| | | | | | |
|--|----------------|-------|---|---|---|
| INPUT VOLTS | 120 | 277 | | | |
| CIRCUIT TYPE | HX-HPF | | | | |
| POWER FACTOR (min) | 90% | | | | |
| REGULATION | | | | | |
| Line Volts | ±5% | | | | |
| Lamp Watts | ±10% | | | | |
| LINE CURRENT (Amps) | | | | | |
| Operating..... | 0.27 | 0.12 | | | |
| Open Circuit..... | 0.85 | 0.40 | | | |
| Starting..... | 0.30 | 0.13 | | | |
| UL TEMPERATURE RATINGS | | | | | |
| Insulation Class | H(180°C) | | | | |
| Coil Temperature Code | 1029 | | | | |
| MIN. AMBIENT STARTING TEMP. | -20°F or -30°C | | | | |
| NOM. OPEN CIRCUIT VOLTAGE | 315 | | | | |
| INPUT VOLTAGE AT LAMP DROPOUT..... | 45 | 100 | | | |
| INPUT WATTS | 30 | | | | |
| RECOMMENDED FUSE (Amps)..... | 3 | 2 | | | |
| CORE and COIL | | | | | |
| Dimension (A) | 1.00 | | | | |
| Dimension (B) | 2.40 | | | | |
| Weight (lbs.) | 4.5 | | | | |
| Lead Lengths | 12" | | | | |
| CAPACITOR REQUIREMENT | | | | | |
| Microfarads | 5.0 | | | | |
| Volts (min.) | 250 | | | | |
| Fault Current Withstand (amps) | | | | | |
| 60 Hz TEST PROCEDURES (Refer to Philips Lighting Electronics N.A. TEST Procedure for HID Ballasts - Form 127 High Potential Test (Volts) | | | | | |
| 1 minute | 2000 | | | | |
| 2 seconds | 2500 | | | | |
| Open Circuit Voltage Test (Volts) | 280-350 | | | | |
| Short-Circuit Current Test (Amps) | | | | | |
| Secondary Current | 0.30-0.40 | | | | |
| Input Current..... | 0.10- | 0.05- | - | - | - |
| | 0.20 | 0.10 | | | |

Capacitor: 7C050L33

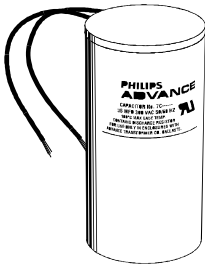

Capacitance: 5
 Dia/Oval Dim: 1.25
 Height: 2.9
 Temp Rating: 105°C



Wiring Diagram:

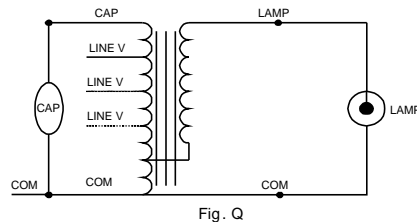

Fig. Q

Typical Ordering Information

(please call Philips Lighting Electronics N.A. for suffix availability)

Order Suffix

Description

Ignitor: NA

This ballast does not require the use of an ignitor.

Data is based upon tests performed by Philips Lighting Electronics N.A. in a controlled environment and is representative of relative performance. Actual performance can vary depending on operating conditions. Specifications are subject to change without notice.

PHILIPS LIGHTING ELECTRONICS N.A.

10275 WEST HIGGINS ROAD · ROSEMONT, IL 60018

Tel: 800-322-2086 · Fax: 888-423-1882 · www.philips.com/advance

Customer Support/Technical Service: 800-372-3331 · OEM Support: 866-915-5886

Revised: 12/04/09