



FF100



JOB NAME: _____
 DATE: _____
 TYPE: _____

DESCRIPTION

Compact, tough and good looking cast aluminum housing with hinged framed glass lens. Integra Hood glare shield and stainless steel clip. 35 to 150 watt HPS, 50 & 70 watt Pulse Start Metal Halide. Lamp supplied.

SPECIFICATIONS

UL Listing

Suitable for wet locations. Suitable for mounting within 4' of the ground

Sockets

Porcelain with all copper current carrying components

Housing

Precision die cast aluminum, 1/2" NPS threaded arm with locking swivel fits all standard mounting boxes

Reflector

Anodized semi-specular aluminum

Lens

Thermal tempered shock resistant glass

Lens Gasket

High temperature tubular silicone set in die cast retaining groove remains in place during relamping

Socket

Glazed porcelain 4kv pulse rated with nickel plated screw shell and spring contacts

Finish

Chip and fade resistant polyester powder coating

EPA

0.43

Patents

Pat. D420,458

Color

Bronze

Weight

7.5

ORDERING INFORMATION

High Pressure Sodium
 Lamp supplied with fixture

Total Watts	Lamp Type	Lamp Base	Ballast
100	ED17	Medium	R-NPF 120V

Starting Amps/ Operating Amps			
120V	208V	240V	277V
3.1/2.1			

Input Watts	LAMP			Initial Lumens	Lamp Hours
	ANSI	HPS	MH CFL		
115.0	S54	9500	24000		

Factory Installed Options
 Add suffix to Catalog Number

Swivel Photocontrol (/PCS)
 Single fusing for 120 and 277 volt (/F)

Double fusing for 208 and 240 volt. (/FF)
 Button Photocontrol (/PC)

Note: Specifications may change without notice

RAB Lighting, Inc. • 170 Ludlow Ave • Northvale, NJ 07647 • Tel: 888 RAB-1000 • Fax: 888 RAB-1232 • www.rabweb.com
 © 2011

DIMENSIONS

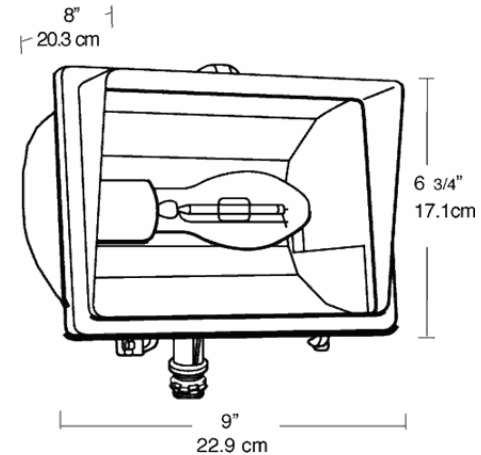

PHOTOMETRIC

150w HPS @ 10' Mounting Height
 Aimed 30° below horizontal

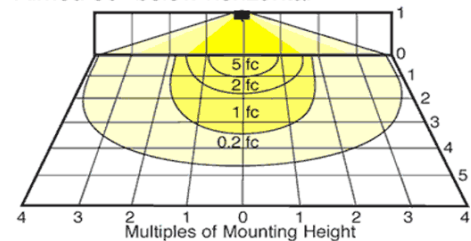

Mounting Height	Multiplier
8'	1.6
10'	1.0
12'	.7
16'	.4
20'	.25

Watts	Multiplier	
	HPS	MH CFL
150	1	
100	.6	.6
70	.4	.4
50	.3	.2
35	.15	
42		.2