

DIMENSIONS AND DATA

4 1/4 X 4 3/4 CORE - 2 COIL UNIT

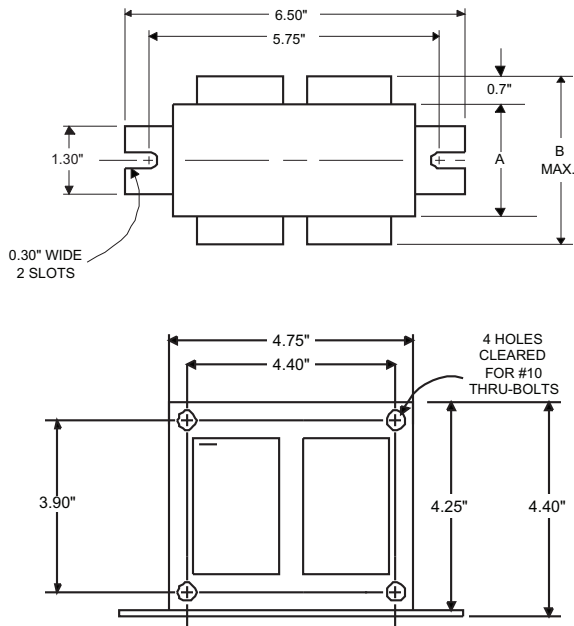

INPUT VOLTS	277				
CIRCUIT TYPE	CWA				
POWER FACTOR (min)	90%				
REGULATION					
Line Volts	±10%				
Lamp Watts	WITHIN TRAPEZOID				
LINE CURRENT (Amps)					
Operating.....	1.70				
Open Circuit.....	0.85				
Starting.....	1.40				
UL TEMPERATURE RATINGS					
Insulation Class	H(180°C)				
Coil Temperature Code	1029	D			
MIN. AMBIENT STARTING TEMP.	-40°F or -40°C				
NOM. OPEN CIRCUIT VOLTAGE	190				
INPUT VOLTAGE AT LAMP DROPOUT.....	208				
INPUT WATTS	457				
RECOMMENDED FUSE (Amps).....	5				
CORE and COIL					
Dimension (A)	2.30				
Dimension (B)	4.00				
Weight (lbs.)	13.5				
Lead Lengths	12"				
CAPACITOR REQUIREMENT					
Microfarads	55.0				
Volts (min.)	240				
Fault Current Withstand (amps)					
60 Hz TEST PROCEDURES (Refer to Philips Lighting Electronics N.A. TEST Procedure for HID Ballasts - Form High Potential Test (Volts)					
1 minute	2000				
2 seconds	2500				
Open Circuit Voltage Test (Volts)	170-210				
Short-Circuit Current Test (Amps)					
Secondary Current	6.00-7.40				
Input Current.....	1.00	-	-	-	-
	1.55				

Capacitor: 7C550P24



Capacitance: 55
Dia/Oval Dim: 1.75
Height: 5.15
Temp Rating: 105°C

Ignitor: LI501-H4

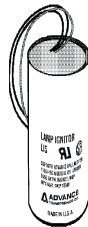

Ballast to Lamp Distance
(BTL) = 2 feet
Temp Rating: 105°C

Wiring Diagram:

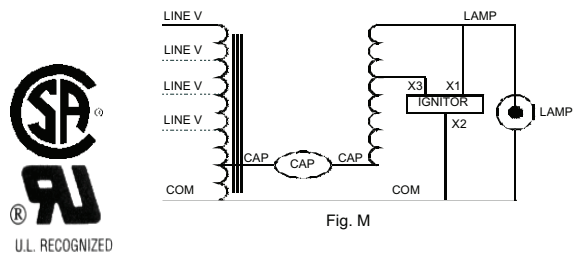

Typical Ordering Information

(please call Philips Lighting Electronics N.A. for suffix availability)

Order Suffix	Description

Data is based upon tests performed by Philips Lighting Electronics N.A. in a controlled environment and is representative of relative performance. Actual performance can vary depending on operating conditions. Specifications are subject to change without notice.

PHILIPS LIGHTING ELECTRONICS N.A.

10275 WEST HIGGINS ROAD · ROSEMONT, IL 60018

Tel: 800-322-2086 · Fax: 888-423-1882 · www.philips.com/advance

Customer Support/Technical Service: 800-372-3331 · OEM Support: 866-915-5886

Revised: 09/23/08