

**PHILIPS
ADVANCE**

**Metal
Halide
Lamp Ballast**

**Catalog Number 71A5792
For 250W M138/M153 (P.S.)
60 Hz SUPER-CWA
Status: Active**

DIMENSIONS AND DATA

4 1/4 X 4 3/4 CORE - 2 COIL UNIT

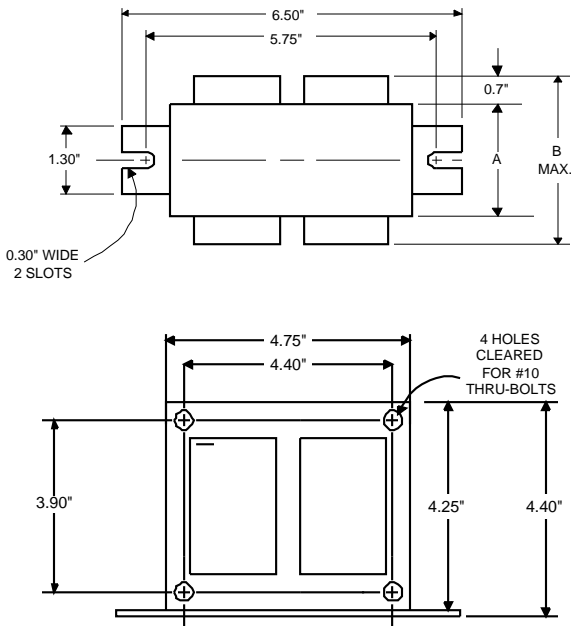

INPUT VOLTS		120	208	240	277
CIRCUIT TYPE	SUPER-CWA				
POWER FACTOR (min)	90%				
REGULATION					
Line Volts	±10%				
Lamp Watts	±10%				
LINE CURRENT (Amps)					
Operating.....		2.50	1.45	1.25	1.10
Open Circuit.....		1.40	0.80	0.70	0.65
Starting.....		1.90	1.10	0.96	0.85
UL TEMPERATURE RATINGS					
Insulation Class	H(180°C)				
Coil Temperature Code	1029	A	A	A	B
MIN. AMBIENT STARTING TEMP.	-30°F or -35°C				
NOM. OPEN CIRCUIT VOLTAGE	275				
INPUT VOLTAGE AT LAMP DROPOUT.....		60	104	120	138
INPUT WATTS	291				
RECOMMENDED FUSE (Amps).....		8	5	5	3
CORE and COIL					
Dimension (A)	1.50				
Dimension (B)	3.10				
Weight (lbs.)	9.5				
Lead Lengths	12"				
CAPACITOR REQUIREMENT					
Microfarads	17.0				
Volts (min.)	400				
Fault Current Withstand (amps)					
60 Hz TEST PROCEDURES (Refer to Philips Lighting Electronics N.A. TEST Procedure for HID Ballasts - Form High Potential Test (Volts)					
1 minute	1500				
2 seconds	2500				
Open Circuit Voltage Test (Volts)	250-300				
Short-Circuit Current Test (Amps)	2.38-2.90				
Secondary Current					
Input Current.....		1.58	0.90	0.80	0.68
		2.40	1.35	1.20	1.05

Capacitor: 7C170P40



Capacitance: 17
Dia/Oval Dim: 1.75
Height: 3.75
Temp Rating: 105°C

Ignitor: LI533-H4



Ballast to Lamp Distance
(BTL) = 5 feet
Temp Rating: 105°C

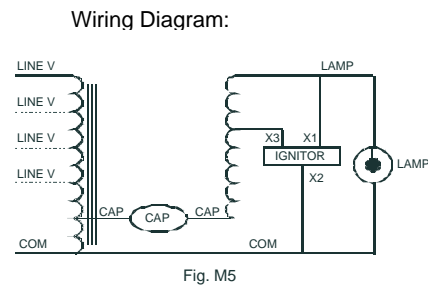

Typical Ordering Information

(please call Philips Lighting Electronics N.A. for suffix availability)

Order Suffix	Description
500D.	Ballast With Ignitor and Dry Film Capacitor
510D.	Ballast w/Welded Bracket, Ignitor, & Dry Film Capacitor
600.	Ballast and Ignitor, No Capacitor
610.	Ballast with Welded Bracket and Ignitor, No Capacitor

Data is based upon tests performed by Philips Lighting Electronics N.A. in a controlled environment and is representative of relative performance. Actual performance can vary depending on operating conditions. Specifications are subject to change without notice.

PHILIPS LIGHTING ELECTRONICS N.A.

10275 WEST HIGGINS ROAD · ROSEMONT, IL 60018

Tel: 800-322-2086 · Fax: 888-423-1882 · www.philips.com/advance

Customer Support/Technical Service: 800-372-3331 · OEM Support: 866-915-5886

Revised: 11/22/05