

Recessed Housing Compatibility

- The LR6-DR series is designed to install in the H6 pan assembly from Cree and other 6" recessed housings from select manufacturers
- For a list of compatible housings please reference www.CreeLEDLighting.com.

Compatibility of housings not on this list may be determined by measurement of the housing as detailed in the attached drawing (Fig. 1).

NOTE: It is necessary to remove the socket and install the GU24 whip if fixture doesn't contain a GU24 socket.

NOTE: Not all existing recessed housings that meet these requirements will be compatible with the LR6. To ensure compatibility, a test installation should be completed.

WARNING - Risk of fire or electric shock. Install this product only in the compatible housings listed above. Do not make or alter any open holes in an enclosure of wiring or electrical components during installation.

WARNING - To prevent wiring damage or abrasion, do not expose wiring to the edges of sheet metal or other sharp objects.

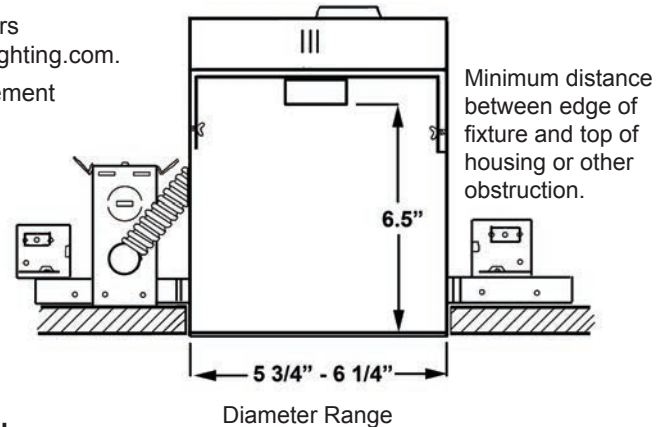
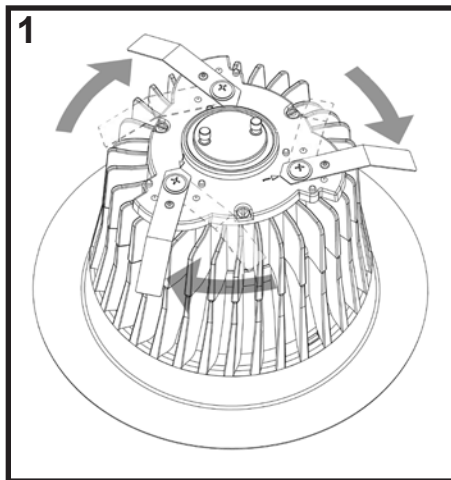

Figure 1

Retrofit Module Installation



1. Remove LR6 Fixture from the packaging and rotate the "Flip Clips" **clockwise** until the pointed tip of the clip lines up with the arrow on the metal base. This position is the installation ready position.

2. Make sure the power is turned off at the source to the recessed housing(s) that you are installing the fixture(s) in.

*For new construction installations with the H6 pan assembly, or for installation into other GU24 based cans, skip to step #5.

3. Once power has been **turned off**, remove existing trim and CFL or Incandescent bulb revealing the screw-in Edison style socket.

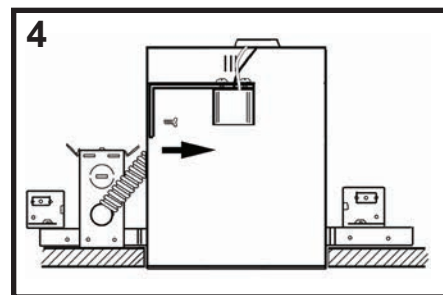

4. Locate the Edison style screw socket in your existing recessed housing and remove any screws that prevent the socket bracket from being removed.

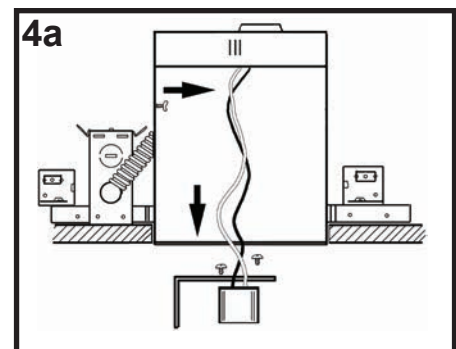

4a. Pull socket assembly including the bracket as low as possible given the existing wire length available. (May require socket plate removal) Remove any

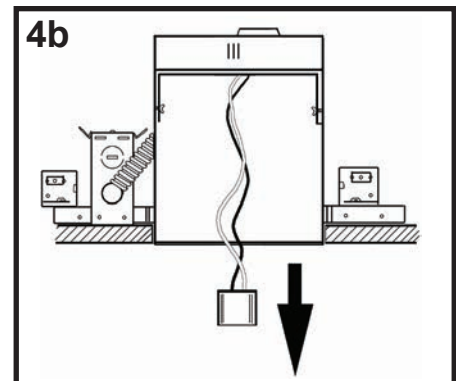

4b. Once you have removed the excess bracketry from the Edison socket.

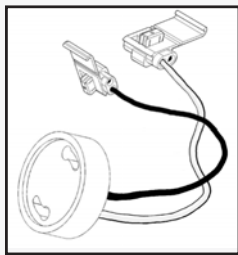

GU-24 Socket Whip
(Provided on LR6-GU24,
LR6C-GU24 Units Only)

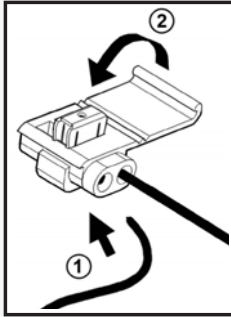

GU-24 Whip Installation: 1. Insert the input wires into the Insulation Displacement Connectors provided on the GU-24 Socket whip and clamp down on the metal u-connector until flush with the top of the plastic insulator.

2. Close plastic hinged cover and snap lock.

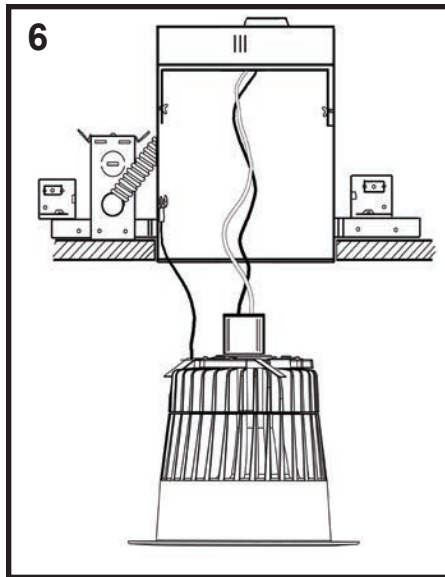

6. Loosen existing metal screw in recessed housing to attach ground wire. Unbind ground wire and hook end of wire around loosened metal screw connected to metal recessed housing. Tighten screw to hold ground hook securely to housing.

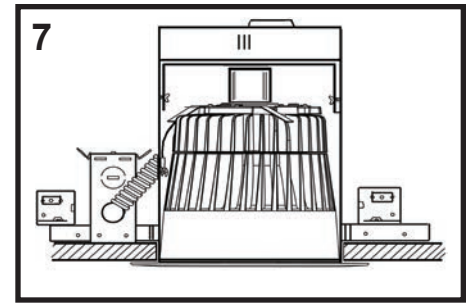

7. Slide attached LR6 with clips in ready position up into the recessed housing until trim ring is flush with ceiling.

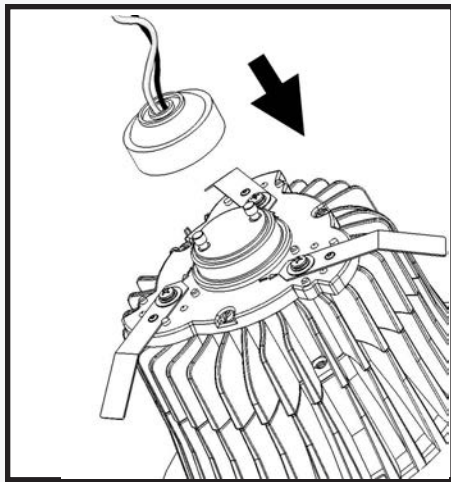

5. Attach whip socket to the LR6 by inserting pins into the socket and twisting socket until locked.

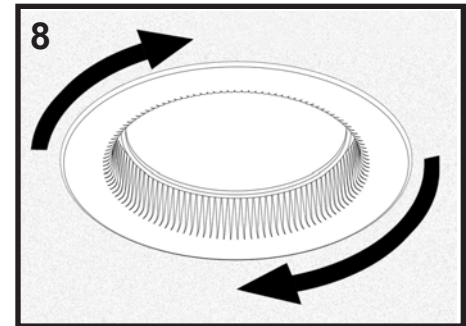

8. Rotate LR6 Fixture 1/4 turn clockwise to lock clips into position. Your LR6 fixture should now be securely installed into the ceiling. Turn power back on and enjoy.

NOTE: This device is not intended for use with emergency exit fixtures or emergency exit lights.

Removal of Installed LR6 Fixture

Should you need to remove the LR6 fixture from the recessed installation follow these steps:

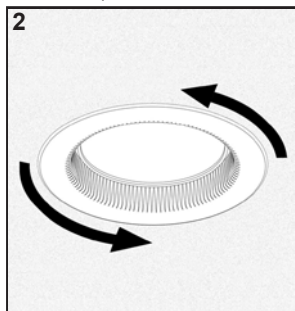

1. Make sure power is turned off at the source to the fixture.

2. Rotate LR6 Fixture 1/4 turn counterclockwise to unlock clips from recessed can.

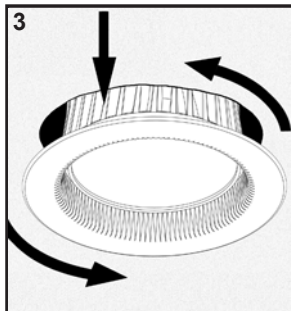

3. Continue to turn fixture counterclockwise as you pull downward on the LR6. This will dis-engage the clips allowing the LR6 to pull free.

4. Detach LR6 from recessed housing socket and remove ground wire.

LIMITED WARRANTY

The limited warranty set forth below is given by Cree, LED Lighting Solutions, Inc. ("CreeLLS") with respect to the lighting product packaged with this limited warranty (the "Product"). Your Product, when delivered to you in new condition in its original packaging, is warranted against defects in materials or workmanship as follows: for a period of three (3) years from the date of original purchase, defective parts or a defective Product returned to CreeLLS, or its authorized service providers, as applicable, and proven to be defective upon inspection, will be repaired, or exchanged for a new Product, as determined by CreeLLS, or the authorized service provider. This limited warranty covers all defects encountered in normal use of the Product, and does not apply in the following cases: (a) Loss of or damage to the Product due to abuse, mishandling, alteration, accident, electrical current fluctuations, failure to follow operating, maintenance or environmental instructions prescribed by CreeLLS in writing or services performed by someone other than CreeLLS or an authorized service provider. **WARRANTY IS VOID IF PRODUCT IS NOT USED FOR THE PURPOSE FOR WHICH THIS PRODUCT IS MANUFACTURED.** Any complaints you may have regarding the product should be addressed to Cree, LED Lighting Solutions, Inc., Keystone Technology Park VI, 635 Davis Drive, Suite 100, Morrisville, NC 27560.

NO IMPLIED WARRANTY, INCLUDING ANY IMPLIED WARRANTY OF MERCHANTABILITY OR FITNESS FOR A PARTICULAR PURPOSE, APPLIES TO THE PRODUCT AFTER THE APPLICABLE PERIOD OF THE EXPRESS LIMITED WARRANTY STATED ABOVE, AND NO OTHER EXPRESS WARRANTY OR GUARANTY, EXCEPT AS MENTIONED ABOVE, GIVEN BY ANY PERSON OR ENTITY WITH RESPECT TO THE PRODUCT SHALL BIND CREE LLS. (SOME STATES AND PROVINCES DO NOT ALLOW LIMITATIONS ON HOW LONG AN IMPLIED WARRANTY LASTS, SO THE ABOVE LIMITATION MAY NOT APPLY TO YOU.)

This device complies with part 15 of the FCC Rules. Operation is subject to the following two conditions: (1) This device may not cause harmful interference, and (2) this device must accept any interference received, including interference that may cause undesired operation.

CAUTION:

Any changes or modifications not expressly approved by the party responsible for compliance could void the user's authority to operate the equipment.



U.S. Patent # 7,213,940; D571038
U.S. and Foreign Patents Pending
Designed and Engineered in the U.S.A.

www.CreeLEDLighting.com

LPN00025
Rev.C