

Model Number: Accessories: Job:	Approvals:  Type:
---------------------------------------	-------------------------

**FEATURES**

- Unique, adjustable "Light Bar" emergency lighting with ultra-bright, energy efficient white LEDs
- Total power consumption is only 1.5 watts
- Compact, low profile design
- Easy to install, snap together design
- Rugged, injection-molded UL94 V-0 flame retardant, high-temperature thermoplastic housing
- Remote capable - up to 2 CLED remote heads
- Universal style - includes 2 face plates, a back plate and mounting canopy
- Charge rate/power "ON" LED indicator light with test button
- Low voltage disconnect eliminates deep discharge
- Brown-out, short circuit and voltage surge protection
- Overcharge protection
- Maintenance-free NiCad battery
- Universal J-Box mounting system - Ceiling, wall or end mount
- UL listed 90 minute emergency run time, 24 hour recharge time
- Constant, uniform illumination by long-life, high intensity, red or green LEDs
- Fully-illuminated 6" characters with 3/4" stroke
- Optional Guardian Self-Test/Self-Diagnostics (G2) available
- Chevron-style, universal arrow knockouts
- 120/277V dual primary, 60Hz input
- Standard finishes: Black or white
- Suitable for damp location



Unique "Light Bar" design combines LED exit illumination with reliable, low-profile LED emergency lighting. The Revolution series offers maintenance-free, long life dependable service, and easily mounts above doors and in restricted spaces to fit any application.



**WARRANTY**

Any component that fails due to manufacturers defect is guaranteed for 3 years with a separate 5 year pro-rated warranty on the battery. The warranty does not cover physical damage, abuse or acts of God. Manufacturer reserves the right to charge for such repairs if deemed necessary.

SPECIFICATIONS ARE SUBJECT TO CHANGE WITHOUT NOTICE

**ORDERING INFORMATION Example: CLED-U-WH-G2**

Series	Style	Finish	Options (Factory Installed)	Accessories <sup>2</sup> (Field Installed)
CLED = Red	1 = Single Face	WH = White	G2 = Self-Test/Self-Diagnostics	WG-1 = Wire Guard (Back Mount)
GCLED = Green	U <sup>1</sup> = Universal	BL = Black		WG-2 = Wire Guard (End Mount)
				WG-3 = Wire Guard (Ceiling Mount)
				XG-6 = Poly Guard (Back Mount)

<sup>1</sup> Universal includes 2nd exit face and backplate

<sup>2</sup> Order as separate line item

## CONSTRUCTION

The CLED series is constructed of a precision-molded housing constructed of 5VA flame retardant, corrosion proof, UV stable thermoplastic. N.F.P.A. approved Field-selectable chevrons. Units resist denting, peeling, scratching and corrosion.

Stencil letters are 6" high with 3/4" stroke, with minimum of 100 ft viewing distance rating as required by UL924 standard.

## ILLUMINATION

Fully illuminated 6" letters with 3/4" stroke is achieved with high output, long lasting red or green Light Emitting Diodes (LEDs). An exclusive color-matched diffuser eliminates hot spots and striations, providing optimal light output. LEDs are a maintenance-free solution, providing up to 100,000 hours of use without failure.

## EMERGENCY LIGHTS

Light bar features ultra-bright white LEDs consuming 1.5W. Wattage is 4.5W when in emergency mode.

## ELECTRICAL

### Input

Dual-voltage input 120 or 277VAC @ 60Hz.

### Sealed Nickel Cadmium Battery – NiCad (With Battery Only)

Exitronix sealed nickel cadmium batteries are maintenance-free with a life expectancy of 15 years. Nickel cadmium batteries offer high discharge rates and continue to perform in a vast temperature range from 0-40 degrees C. NiCad technology provides long lasting, safe and reliable performance by utilizing the jelly-roll design and allows a Ni-Cad cell to deliver a much higher maximum current than an equivalent size alternative battery. As a relatively larger area of the electrode is in contact with the active material in each cell, the internal resistance for an equivalent sized NiCad cell is lower which increases the maximum current that can be delivered.

### Emergency

The 500 series exit will operate for a minimum of 90 minutes during a loss of power with a 24 hour maximum recharge time for the battery. An extended 120 minute battery is available.

### Brownout Circuit

The brownout circuit monitors the flow of AC current to the unit and triggers the emergency lighting system once a set reduction of AC power occurs. This dip in the voltage will cause many fixtures to extinguish causing loss of normal lighting even though a total power failure has not occurred.

### Low Voltage Disconnect

When the battery's terminal voltage falls below predetermined levels, the low-voltage circuit disconnects the emergency lighting load. The disconnect remains in effect until normal power is restored, preventing deep battery discharge and improving the life of the battery. The disconnect will also automatically reconnect the load circuit once the battery voltage returns to a normal value after charging.

### Solid-State Transfer

The unit features a solid-state switching transistor which eliminates damaged contacts or mechanical failures associated with relays. The switching circuit is designed to detect a loss of AC power and automatically energizes the lamps. Upon restoration of the AC voltage, the emergency lamps will switch off and the charger will automatically recharge the battery.

### Overload and Short-Circuit Protection

The solid-state overload monitoring system in the DC circuit disconnects the lamp load from the battery should excessive wattage demands be made and automatically resets when the overload or short-circuit is removed. This overload current protective characteristic eliminates the need for fuses or circuit breakers for the DC load.

### Test Button

Our easily located test button allows for manual verification of proper operation of the transfer circuit and emergency lamps.

## INSTALLATION

Simple snap together universal design allows for faceplate and back plate to be fully interchangeable. Mounting canopy is supplied with all signs and snaps into enclosure with two positive locking tabs.

## Damp Location Rated - Standard

Damp location rating ensures the fixture is designed to operate safely in outdoor locations that are protected from the direct elements. Damp location rated fixtures may be installed indoors. Products with damp location ratings are not designed to withstand constant or significant moisture or direct contact with water or steam.

## Remote Capable (Standard)

This unit comes standard with an additional 2.2 watts of remote for use with up to (2) CLED lamps.

## Guardian Self-Test/Self-Diagnostics – (Option: G2)

The Guardian circuit continuously monitors the operating condition of the AC power, battery supply voltage, emergency lamp continuity and charging circuit.

The purpose of this option is to provide visual signaling in response to a fault at the EXIT sign battery and/or battery charger. If a failure is detected, visual status will occur immediately via the CHARGER LED and/or the BATTERY FAULT LED. The LEDs will stay illuminated until the fault is corrected.

The Guardian circuit also monitors the transfer circuit as well as performing automatic code compliant testing. The Guardian circuit will perform a 30 second discharge and self-test every 28-30 days. A 90 minute discharge and self-test is performed every 6 months.

## CONFORMANCE TO CODES & STANDARDS

The CLED Series is UL listed and meets or exceeds the following: UL 924, NEC requirements and NFPA 101.

## REMOTE LAMPS (Order Separately)

### FEATURES

- Each lamp contains 8 long lasting, efficient ultra-bright white LEDs
- For use with VLED-EL90 or CLED combo units only
- Wet location option available



Single Lamp with Weatherproof (WP) Option



Double Lamp with No Options

## REMOTE ORDERING INFORMATION

Example: CLED-G2

Series	Options
CLED = Single Remote Lamp	G2 = Self Test / Diagnostics
2CLED = Double Remote Lamp	WP = Weatherproof Applications

Order remote lamps as separate line item

Remote lamps with G2 option are compatible with LED combo units with G2 option only.

### SAMPLE PHOTOMETRICS

Using multiple units mounted at a typical 7.5' delivers 16' center-to-center spacing on a 3' wide egress path.

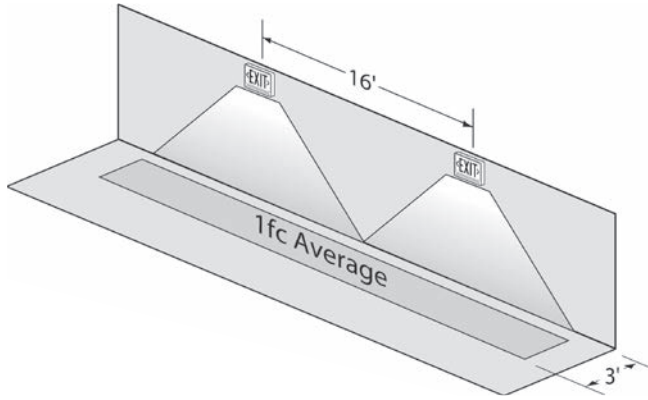

### DIMENSIONS

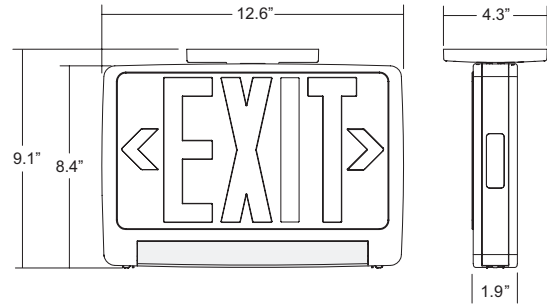

Using multiple units mounted at a typical 7.5' delivers 12' center-to-center spacing on a 6' wide egress path.

