

Specifications:

Lamp Type	Two 5.4W DC T5, wedge-base
Lamp Wattage	120VAC, 60Hz, 0.060A, 6.7W
	277VAC, 60Hz, 0.031A, 7.3W
Emergency Operation	90 minutes

Listings & Certifications:



Model: FHEM11



Mechanical Data:

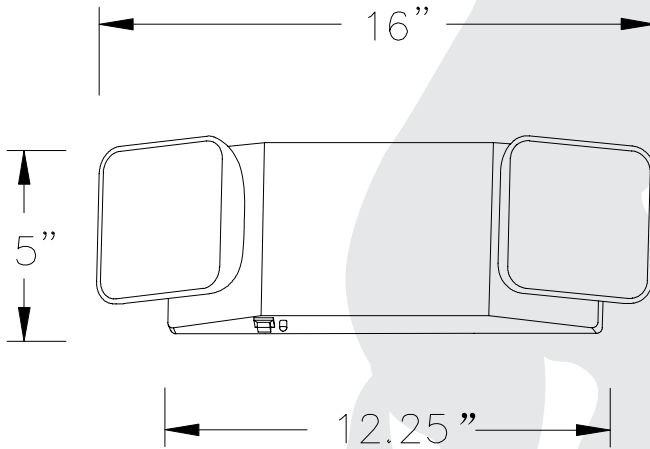

Standard Features:

- Push-to-test Switch
- LED Charge Indicator
- Maintenance free, 6V sealed lead-acid battery
- Dual Voltage 120V/277V
- Specification Grade Design
- Universal Mount
- Fully adjustable glare free lighting heads
- Universal mounting pattern knockout in backplate for J-box mounting
- Automatic Low Voltage Disconnect (LVD)
- Damp Location Listed

Ordering Information:

Base Model No.	Case Color	Options
FHEM11	W - White	SD - Self Diagnostic
		H - High Lumen Reflector
	B - Black	RC - Remote Capable

Build part number by adding Base Model No., one of each Case Color, and desired options code(s).
 Example: FHEM11-W-SD