

51110-001 Residential Surge Protection Panel

APPLICATION

The 51110-001 Residential Surge Protection Panel is designed for mounting at the service entrance in homes, apartments and condominiums. It offers advanced surge protection for modern electronics and appliances, reducing the risk of damage from spikes and surges entering the property through AC power lines.



SPECIFICATION

The 51110-001 Residential Surge Protection Panel (SPD Type 2) shall be designed for use on 240/120V, 50/60 Hz single-phase AC power lines. The unit shall provide type 4X housing for indoor and outdoor installations.

FEATURES

- Surge protection for 240/120V, 50/60 Hz single-phase AC power lines
- Real-time diagnostic visual indicator shows power and suppression status for each protected phase
- UL1449 2.5 Edition rated for 400V peak clamping voltage (L-N, L-G, N-G)
- UL1449 3.0 Edition rated for 600V peak clamping voltage (L-N, L-G, N-G)
- Rated for 48kA peak maximum surge current (8 x 20µs) per mode – 96kA per phase
- 150 maximum continuous operating voltage (MOV) rating allows for tolerance to line voltage swells
- DHC Power Line Carrier compatible
- Separate surge suppression indicator lights stay on for Phase 1 and Phase 2 until protection is lost

DESIGN CONSIDERATIONS

- 4X enclosure
- Painted metal, flush-mount collar

STANDARDS COMPLIANCE

Meets or exceeds all applicable standards:

- ANSI/IEEE Categories B and C, C62.41 and C62.45
- UL 1449 3.0 Edition, #E317603 Indoor & Outdoor Rated
- cULus Listed

ENVIRONMENTAL

Storage Temperature: -20° C to 85° C

Operating Temperature: -10° C to 60° C

WARRANTY INFORMATION

10-year limited product warranty

COUNTRY OF ORIGIN

China

ELECTRONIC FILES

For CAD files, typical specs, or technical drawings (.DXF, .DWG), visit www.leviton.com.

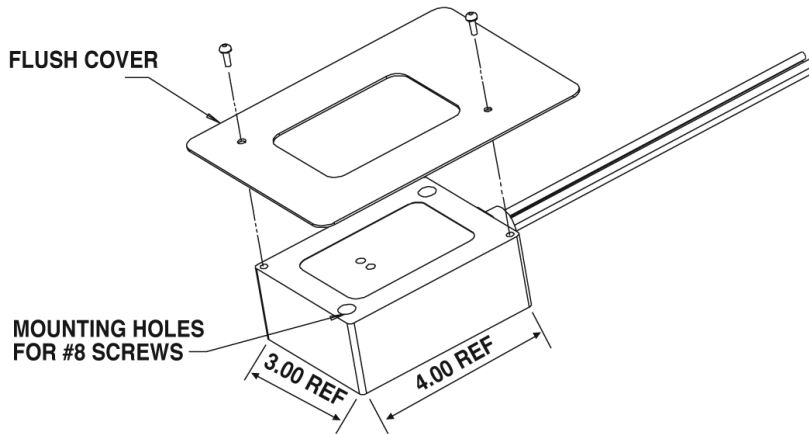

51110-001

PART NUMBERS

Description	Part No.
51110-001 Residential Surge Protection Panel	51110-001



K11 3797

Leviton Network Solutions
2222 - 222nd St. SE
Bothell, WA 98021-4416

tel 1-800-824-3005
tel +1-425-486-2222
appeng@leviton.com
www.leviton.com

Asia / Pacific
T +1.631.812.6228
E infoasean@leviton.com

Europe
T +33.6.8869.1380
E infoeurope@leviton.com

Canada
T +1.514.954.1840
E pcservice@leviton.com

India / SAARC
T +91.80.4322.5678
E infoindia@leviton.com

Caribbean
T +1.954.593.1896
E infocaribbean@leviton.com

Mexico
T +52.55.5082.1040
E lsamarketing@leviton.com

China
T +852.2774.9876
E infochina@leviton.com

Middle East & Africa
T +971.4.886.4722
E lmeinfo@leviton.com

Colombia
T +57.1.743.6045
E infocolombia@leviton.com

South Korea
T +82.2.3273.9963
E infokorea@leviton.com