

IPP15 Application Note

INTRODUCTION

The Decora® IPP15 is a Manual-ON Occupancy Sensor that was developed to comply with California Title 24, Section 119 Mandatory Requirements and Section 150 Residential Lighting Specifications.

The IPP15 installs as a single-pole or 3-Way device and fits in a standard wallbox. It has the added benefit that if you forget to turn the lights OFF, they will turn OFF automatically if motion is not detected within the coverage area (900 sq ft) within the set time out limit. There are four selectable time-out options: 30 seconds (test only), 5, 15 or 30 minutes.

CALIFORNIA TITLE 24

California Title 24 requires that new homes built effective October 1, 2005, be wired with high efficacy lighting (fluorescent and compact fluorescent or high intensity (HID) lamps). If non-high efficacy lighting has been installed, a Manual-ON/Automatic OFF occupancy sensor switch, or a dimmer switch must be installed to comply with the standard. Special lighting requirements for specific rooms are defined in the following chart according to Title 24, Section 150 Residential Lighting. You can read further into these standards by going to: http://www.energy.ca.gov/title24/residential_manual/

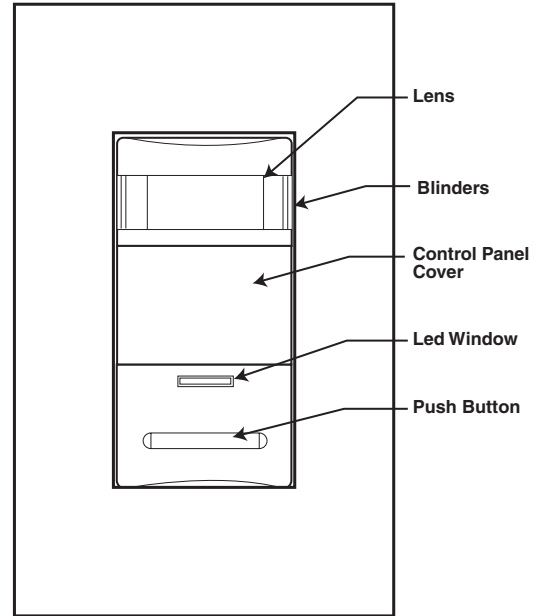

Required Lighting Specifications by Area in Residence

Area	Requirement	Alternate Options
Kitchen	<ul style="list-style-type: none"> High Efficacy Lighting. Electronic ballasts for all lamps rated 13 watts or greater. Recessed luminaries in all insulated ceilings approved for zero clearance insulation cover (IC) and certified airtight. 	<ul style="list-style-type: none"> 50% of total rated wattage must be high efficacy luminaries Remaining 50% may be Manual-ON/Automatic OFF Occupancy Sensors or dimmers, provided that they are controlled by switches separate from those controlling the high efficacy lighting
Living/Family Room Dining Room Bedroom Hallway/Stairs	<ul style="list-style-type: none"> Switches controlling high efficacy lighting must be separate from switches controlling low efficacy lighting. 	<ul style="list-style-type: none"> Manual-ON/Automatic OFF Occupancy Sensor Dimmer
Bathroom Garage Laundry Room Utility Room		<ul style="list-style-type: none"> Occupancy Sensor that is certified to comply with section 119 (d). Must contain Manual-ON/Automatic OFF only and cannot be set in "always ON" state. Permanently installed luminaries that are not high efficacy lighting shall be allowed in closets less than 70 square feet.
Exterior		<ul style="list-style-type: none"> Controlled by a motion sensor AND photo control (lighting NOT attached to a building i.e., landscape lighting, is exempt from this requirement).

Application Note For IPP15

HOW IT WORKS

The IPP15 uses passive infrared (PIR) detection technology which senses heat and temperature differences to monitor a room for occupancy. A specialized Fresnel lens divides the field of view into sensor zones. After the switch has been manually turned ON, when a person moves within the sensor zone, the sensor detects motion and keeps the lights ON. The lights will remain ON as long as there is motion detected.

Manual-ON Operation

The unit will not turn the lights ON automatically when motion is detected. Lights can only be turned ON by manually pressing the push-button. The lights will remain ON as long as the unit detects activity in the sensor zones.

Manual/Automatic-OFF

The IPP15 will shut the lights OFF automatically after the space becomes vacant and the delayed OFF time expires. Lights can also be turned OFF manually at any time by pushing the push-button. If motion is detected within 30 seconds after the lights have turned OFF (due to absence of motion), the lights will turn back ON. If 30 seconds expires when lights have turned OFF (due to absence of motion), the lights will then have to be turned ON manually.

BLINDERS

The blinders reduce the motion detection area when adjusted. This can be useful in rooms that have large open entryways or larger open rooms like a kitchen/dining room combination. By adjusting the blinders to the closed position, the IPP15 will have a narrower field of motion detection. This can be useful when walking through an attached dining room. If undesired motion is still detected after adjusting the blinders you may want to reduce the range. To adjust the blinders, open or close the Blinder Adjustment Levers (Figure 1).

RANGE SELECTIONS

The IPP15 is equipped with five range selections that will apply to any application. Factory default sets the range between 4 and 7. Below is a chart illustrating the distance of a room by length and width and the coverage with the blinders open or the blinders closed. The sample chart below is based on a 15'x20' room with the IPP15 located next to the entrance door. The room was tested to measure the distance limitations on the IPP15 given the range selections. To adjust the range, dial down for a smaller coverage area and up for a larger coverage area (Figure 1 below).

Range from device length x width	Room = 15'Lx20'W	Coverage Area	
	Slash /	Blinders Open	Blinder Closed
4	15'x10'	10'x8'	10'x6'
Factory Default	15'x12'	15'x12'	15'x6'
7	15'x15'	15'x15'	15'x6'
10	>15'x20'	>15'x20'	15'x6'

To program the range, time-out interval and adjust the blinders, remove the wallplate and remove the control panel cover with a small flathead screwdriver (Figure 1).

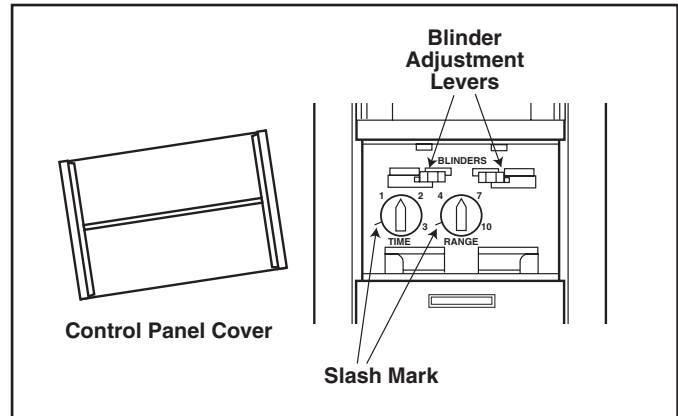

Figure 1

INSTALLATION CONSIDERATIONS

WALLBOX

- An extended depth wallbox is recommended for installing the IPP15 device. For proper mounting of device there must be adequate room for wires.
- A minimum of 18 cubic inches (3 inches depth) is recommended for a single gang box.
- Verify that wallbox is not skewed when installed.
- Wallbox must be level and flush to wall surface or recessed in order for proper fit.

WIRING DIAGRAM FOR IPP15

- IPP15 is a single-pole or 3-Way circuit switch that requires a Neutral (white) wire connection. There must be a neutral wire present in the wallbox for the device to operate correctly.

Single Pole Wiring Diagram

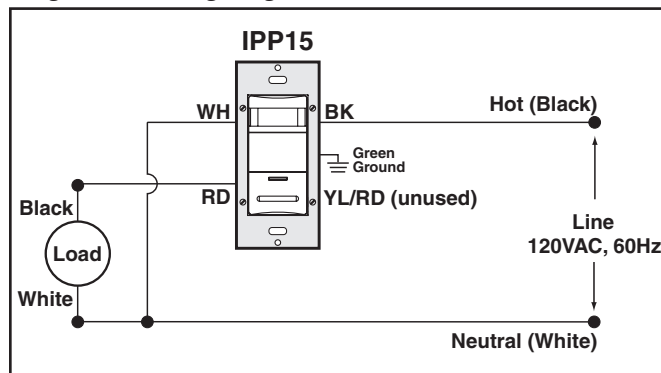

3-WAY APPLICATIONS

Wiring this device in a 3-Way application offers various different scenarios depending on the size or layout of your room. Areas that may require 3-Way control are bathrooms, basements, garages, utility/laundry rooms, hallways, bedrooms, and kitchens. Your sensor may be located in an area that does not cover the entire room, this could be depending on the way the switch is facing in the room, or the size of the room exceeds the sensors 900 sq ft coverage area. In either instance, a 3-Way circuit can improve your range of coverage and control. Leviton's IPP15 occupancy sensor allows you to wire any 3-Way circuit with either an IPPOR sensor remote or any of Leviton's Vizia™ remote switches.

Maximum wire length from IPP15 to all installed remotes cannot exceed 300 ft (90 m).

IPP15 with IPPOR Matching Sensor Remote

The IPP15 with the IPPOR provides true 3-Way control for large rooms where the sensor does not have coverage of the entire room.

Example: L shaped room, Great Room

3-Way Wiring Diagram for IPP15 with Sensor Remote. Up to 5-Way Control

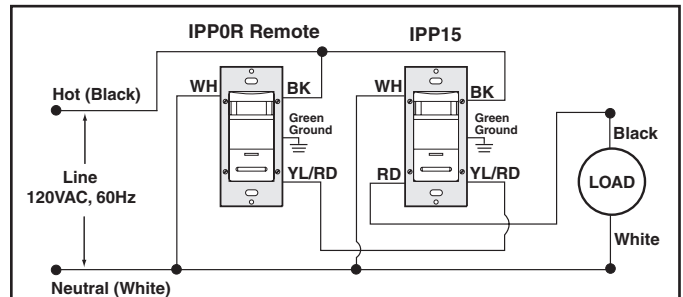

NOTE: The IPP15 **must** be installed in a wallbox that has a Load connection. The matching remote **must** be installed in a wallbox with a Line Hot connection and a Neutral connection. A Neutral wire to the matching remote needs to be added as shown.

IPP15 with VZ0SR-1L Vizia Matching Switch Remote or Coordinating Switch Remote

An IPP15 and a Vizia remote can be used for true 3-Way control for small rooms (<900 sq ft) where the sensor can view the entire room without obstructions.

Example: Jack and Jill Bathroom

In a Jack and Jill bathroom application you may have more than one entrance to the bathroom with a switch at either entrance. This application could be wired using an IPP15 remote at one entrance and a Vizia remote at the other. This would allow control of the load at either end in addition to having occupancy control in the bathroom.

3-Way Wiring Diagram for IPP15 with Vizia Matching Switch Remote. Up to 5-Way Control

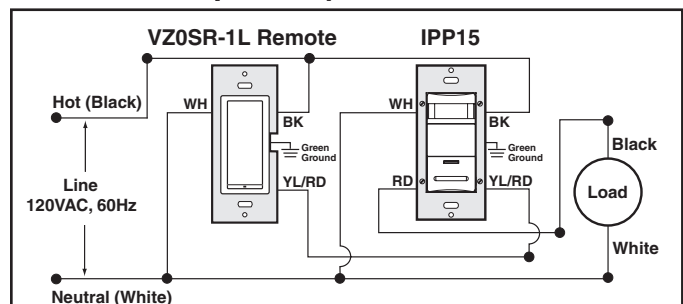

NOTE: The IPP15 **must** be installed in a wallbox that has a Load connection. The matching remote **must** be installed in a wallbox with a Line Hot connection and a Neutral connection. A Neutral wire to the matching remote needs to be added as shown.

Application Note For IPP15

3-Way Wiring Diagram for IPP15 with Vizia Coordinating Switch Remote. Up to 10-Way Control

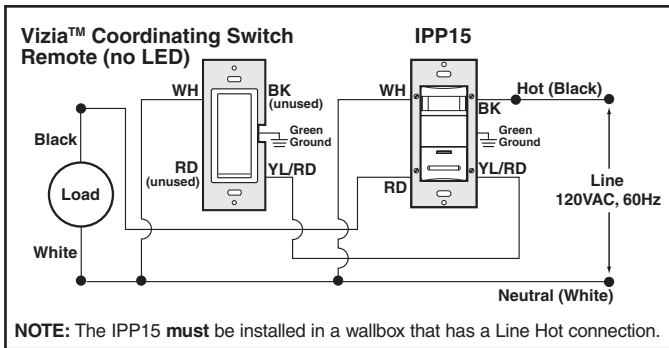

Vizia Dimmer with IPP0R Matching Sensor Remote

A Vizia dimmer can be used with an IPP0R sensor remote for true 3-Way control of small rooms (<900 sq ft) where the sensor can view the entire room without obstructions. This adds dimming functionality. The Vizia dimmer or the IPP0R can be turned ON full bright from the OFF position by pressing and holding the push pad. It also has a 10 second delayed off feature that can be activated from the ON position by pressing and holding the push pad of the dimmer or the IPP0R until the LED starts blinking. Example: Master Bedroom

In addition the IPP0R sensor remote can be used as a remote sensor to any Vizia dimmer or switch device. Below is a scenario where this application might apply.

3-Way Wiring Diagram for IPP0R with Vizia Dimmer. Up to 5-Way Control

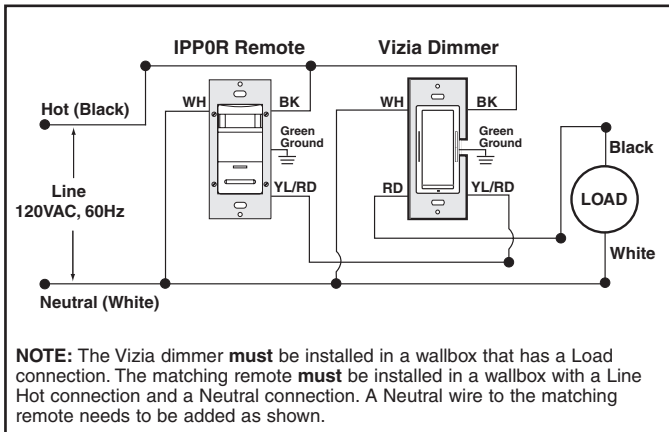

LOCATION OF IPP15

For All Locations

- The IPP15 PIR sensor operates on a line-of-site principle, so it must have a clear, unobstructed view in order to detect occupancy.
- Install at least 6 feet away from a climate control source (i.e. radiators, air exchangers, air conditioners, etc.). Hot or cold drafts can appear to the sensor as body motion.
- Do not install directly under a lighting source that is 100 watts or greater. Temperature changes can be detected by the device.
- The IPP15 can be used for switching incandescent and fluorescent and low voltage lighting with electronic or magnetic ballasts.

Kitchen

- Do not install IPP15 near a stove or appliance that generates heat.
- Install the IPP15 in a location where it will NOT sense motion from an adjoining room (i.e. dining room, great room or family room).

Bathroom

- Make certain a shower curtain or glass shower door do not obstruct the field of view.
- Consider programming the IPP15 with the maximum time out period of 30 minutes before the lights will automatically turn OFF. If you spend more than 30 minutes regularly in the bathroom, consider installing a Leviton dimmer instead.
- Some bathrooms are designed with more than one entrance, which is often described as the "Jack and Jill" bathroom, application. For this scenario, the IPP15 can be wired in a 3-Way application.

Bedroom

- Make certain the blinders are set for full open (default setting).
- Consider programming the IPP15 with the maximum time out period of 30 minutes before the lights will automatically turn OFF. If you spend more than 30 minutes sitting still at a computer, watching TV, or reading, you should consider installing a Leviton dimmer instead.

Laundry/Utility Room or Garage

- A short time out setting is recommended

LED INDICATORS

IPP15 is designed with an LED locator within the manual push button. Depending on the state of the device this LED will respond accordingly.

Lights OFF & NO motion = LED ON

Lights OFF & motion detection = LED ON

Lights ON & NO motion = LED OFF

Lights ON & motion detection = LED Blinks