

INSTALLATION INSTRUCTIONS

EMERGENCY FLUORESCENT BATTERY PACK

MODEL PS300, PSQ500, PS600, PS1400

CAUTION: For safety and proper operation, read and follow instructions carefully before installation.

FIELD INSTALLABLE FLUORESCENT BATTERY PACK IS UNIVERSALLY COMPATIBLE WITH THE BALLASTS AND OPERATING LAMP(S) IN THE LAMP COMPATIBILITY TABLE (PAGE 3).

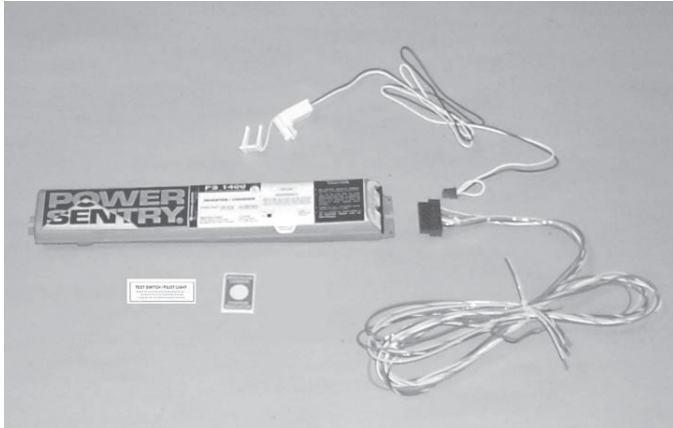

IMPORTANT NOTES:

Make sure that branch circuit feeds are derived from a common phase for both normal lighting ballast and Battery Pack prior to installation.

Notice: To ensure proper grounding, mount unit only with metal cutting screws (not provided).

The Battery Pack can be used with a switched or unswitched (night) circuit. When used with a switched fixture it is important to note that the power to the Battery Pack must be provided by an unswitched circuit.

APPROXIMATE WORKING VOLTAGE
Battery Pack input: 120 OR 277V AC

CAUTION:

A potential electrical shock hazard exists even when AC power supply has been turned off. Disconnect polarized Test Switch/Pilot Light connector before servicing fixture. Do not remove the wire harness connector when AC power is present.

7

IMPORTANT SAFEGUARDS

1. READ AND FOLLOW ALL SAFETY INSTRUCTIONS

2. Before wiring to power supply, turn off electricity at fuse or circuit breaker.
3. Do not disconnect the wire harness with AC power present. To reduce the risk of electrical shock, disconnect AC power and unplug test switch/pilot light connector before servicing.
4. All servicing should be performed by qualified personnel.
5. Consult your local building code for approved wiring and installation.
6. Do not use standard product outdoors. This product is for use with indoor fixtures sealed or unsealed, except air handling heated outlets or hazardous location applications.
7. The emergency ballast must be connected to an unswitched AC power source (120 or 277).
8. Do not mount near gas or electric heater.
9. Do not attempt to service the battery. A sealed no-maintenance battery is used that is not field replaceable. Contact manufacturer for service information.
10. Equipment should be mounted in location and at heights where it will not readily be subjected to tampering by unauthorized personnel.
11. The use of accessory equipment not recommended by the manufacturer may cause an unsafe condition.
12. Do not use this equipment for other than intended use.

SAVE THESE INSTRUCTIONS

Patent Numbers

5,814,971

6,522,147

6,577,136

D550,154

ACCUPRO®

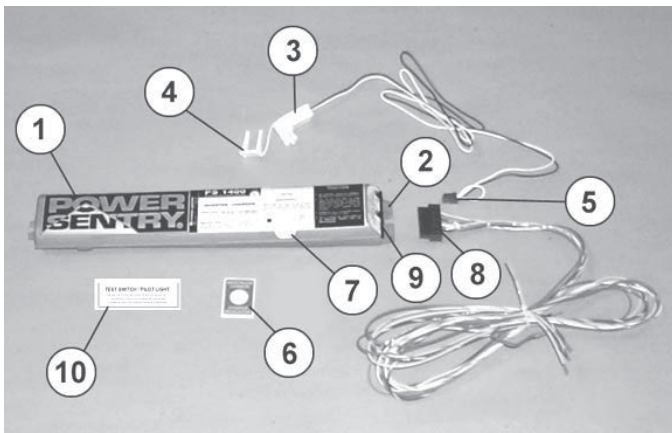

FIGURE 1

PARTS DESCRIPTION

- | | |
|-----------------------------------|--------------------------------------|
| ① HOUSING | ⑦ LAMP SELECTOR SWITCH (PS1400 ONLY) |
| ② MOUNTING HOLES or SLOTS | ⑧ WIRE HARNESS/PLUG |
| ③ TEST SWITCH/PILOT LIGHT (TS/PL) | ⑨ BATTERY PACK POWER CONNECTOR |
| ④ MOUNTING CLIP | ⑩ TS/PL LABEL |
| ⑤ TS/PL CONNECTOR | |
| ⑥ CHARGE INDICATOR STICKER | |

INSTALLATION

1. Turn off AC Power. Inspect Battery Pack and make sure the Test Switch/Pilot Light Connector ⑤ and wire harness connector ⑧ are both disconnected. If still connected, disconnect them before installation.
2. Position unit in fixture wireway and fasten securely through keyed slots or Mounting Holes or Slots ②. If necessary, drill holes and mount with metal cutting screws (not provided).
3. Attach and fully engage the wire harness connector ⑧ to the battery pack power connector ⑨.

CAUTION:
Connector must be fully engaged and latched before AC power is applied.

4. Refer to appropriate wiring diagram. Connect unit to ballast and lamp(s) and A.C. power leads as indicated in appropriate wiring diagram.

TEST SWITCH/PILOT LIGHT (TS/PL) INSTALLATION

CAUTION:

Do not locate Test Switch/Pilot Light ③ or route cable within 1" of fixture lamps.

NOTE: If pilot light is not visible outside the fixture lens, there is a charge indicator sticker ⑥ located in pre-pack that should be placed on the flat side of the lens directly below the test switch pilot light to identify it as an emergency fixture.

1. Drill or punch a 1/2" diameter hole in fixture wall or wireway cover.
2. Insert one side of TS/PL ③ into the hole from the back and snap in the other side. Slide mounting clip ④ firmly onto mounting post to secure TS/PL assembly. Mark the TS/PL location with the TS/PL label ⑩.

3. Connect and fully engage the Test Switch/Pilot Light Connector ⑤ to the battery pack.
4. Apply continuous power to Battery Pack.

INSPECTION AND MAINTENANCE

NOTE: Emergency lighting systems should be tested as often as local codes require, or at least quarterly to insure that all components are operational. Perform all test required by local codes.

1. Check equipment rating to be sure that fixture will receive proper line voltage.
2. Be sure pilot light is on. If pilot light does not operate, check to see that:
 - A. Test Switch/Pilot Light Connector ⑤ is connected.
 - B. AC power is on and wire harness ⑧ is fully engaged into battery pack power connector ⑨.
 - C. Voltage on branch circuit to Battery Pack is rated at line voltage (120V or 277V). If no line voltage can be measured, locate problem in branch circuit and correct.
3. Press test switch. The pilot light ③ should be off. One (all models) or two (PS600 and PS1400 only) fluorescent lamps should be operating at a reduced light output.

NOTE: Allow battery to charge 24 hours before initial testing and 72 hours to fully charge battery.

NOTE: Battery packs are not field serviceable units.

CAUTION:
Damage to battery will occur if Test Switch/Pilot Light connection is made for a prolonged period of time without AC power provided.

CAUTION:
Connecting the Test Switch/Pilot Light Connector also connects the battery to the inverter circuit which can result in high voltage being present between the output leads.



www.powersentrysafety.com
1-888-300-7017

LAMP SELECTOR TABLE - PS1400 ONLY

NOTE: The PS1400 has a lamp selector switch which can be used to optimize performance when placed in the “down” position. However, please note, based on your lamp configuration, the PS1400 can only be placed in the “down” position if so designated in the lamp selector table.

WARNING: Lamp Type/Switch Selector Combinations not listed in the lamp table could damage unit and void warranty.

LAMP DIAMETER	BASE TYPE	POWER (LENGTH)	NUMBER OF LAMPS EMERGENCY	LAMP SELECTOR SWITCH
(T8, T10, T12) 5/8", 1", 1-1/4", 1-1/2"	SINGLE OR BIPIN	14-24W (2'-4')	1	UP
			2	DOWN
(T8, T10, T12) 5/8", 1", 1-1/4", 1-1/2"	SINGLE OR BIPIN	28-40W (2'-4')	1	UP
			2	DOWN
		40-215W (5'-8')	1	DOWN
LONG COMPACT	4-PIN (G11)	18-39W	1	UP
			2	DOWN
		40-55W	1	DOWN
COMPACT	4-PIN	13-26W (QUAD TUBE)	1	UP
			2	DOWN
COMPACT	4-PIN	18-26W TRT (TRIPLE TUBE)	1	UP
			2	UP
COMPACT	4-PIN	32W TRT (TRIPLE TUBE)	1	UP
			2	DOWN
COMPACT	4-PIN	42W TRT (TRIPLE TUBE)	1	DOWN
T5	SINGLE	14-20W (2'-4')	1	UP
T5 & T5HO	SINGLE	24-54W (2'-4')	1	DOWN

Note: Lamp selector switch is located under perforated tab on product label. Battery pack shipped with switch in “DOWN” position.

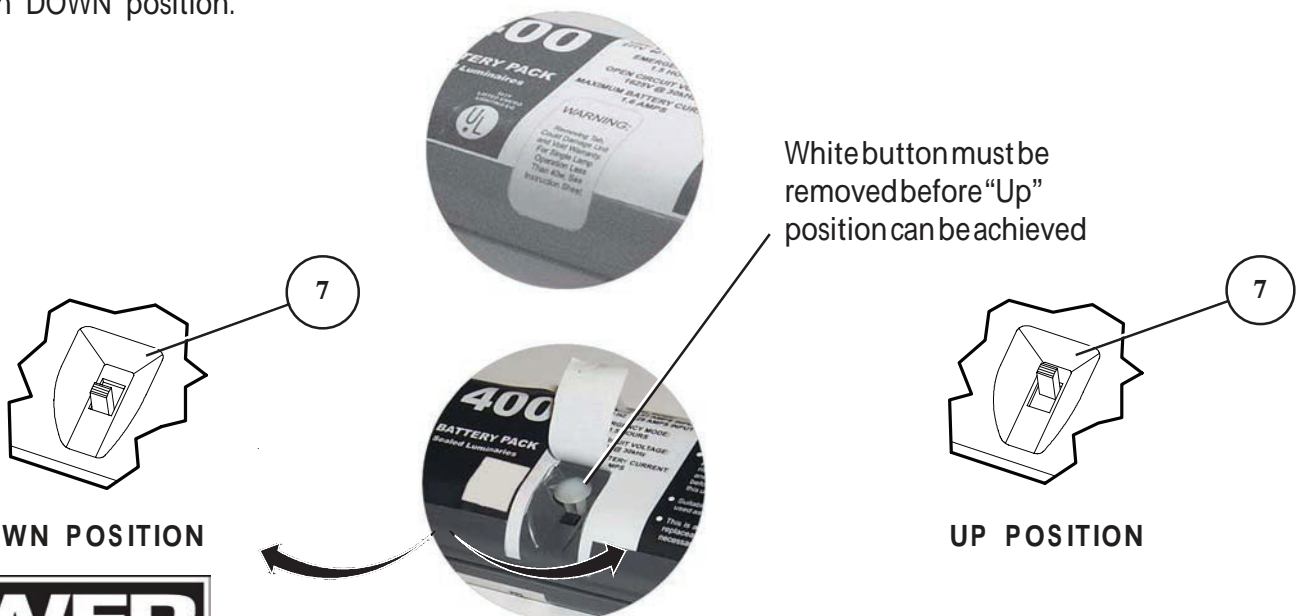

LAMP COMPATIBILITY TABLE

LAMP TYPE	WATTAGE	PS300	PSQ500	PS600	PS1400
		(300 lumens)	(500 lumens)	(600 lumens)	(1100-1400 lumens)
24" - 48" T5	14 - 28				1
24" - 48" HO T5	24 - 54				1
U-LAMPT8	16 - 31	1	1	1,2	1,2
24"-48" T8	17 - 32	1	1	1,2	1,2
60"-96" T8	40 - 59			1	1
96" HO T8	86			1	1
CIRCLINE T9	20 - 40	1		1	1
U-LAMPT12	34 - 40	1	1	1,2	1,2
24"-48" T12	20 - 40	1	1	1,2	1,2
60"-96" T12	50 - 75			1	1
24"-48" HOT12	35 - 60			1	1
60"-96" HO T12	70 - 110			1	1
24"-48" VHO T12	74 - 115			1	1
60"-96" VHO T12	135 - 215			1	1
PL TWIN-TUBE (4-PIN)	9 - 13				1
PL QUAD-TUBE (4-PIN)	13 - 26				1,2
TRIPLE-TUBE (4-PIN)	18 - 32				1,2
TRIPLE-TUBE (4-PIN)	42				1
LONG COMPACT (4-PIN)	18 - 40	1	1	1	1
LONG COMPACT (4-PIN)	50 - 55				1

- 1 - Indicates one lamp operation in emergency mode
- 2 - Indicates two lamp operation in emergency mode

WIRING DIAGRAMS

IMPORTANT NOTES: Before connecting TS/PL connector or wiring unit to fixture, refer to and **IMPORTANT SAFEGUARDS** for safety information and mounting procedures.

INSTALLATION PROCEDURE

ONE LAMP RAPID START BALLAST

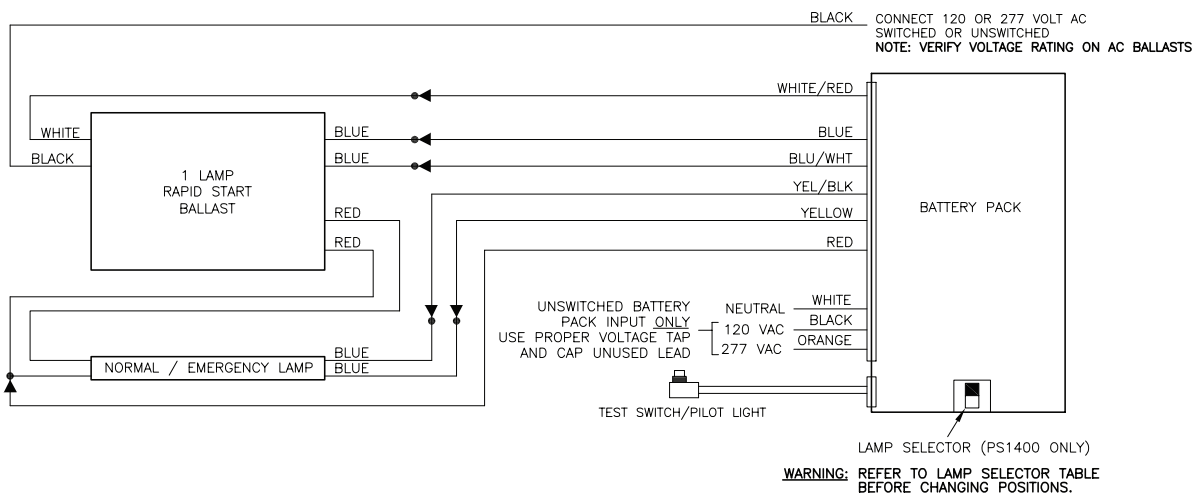

FIGURE A

TWO LAMP RAPID START BALLAST

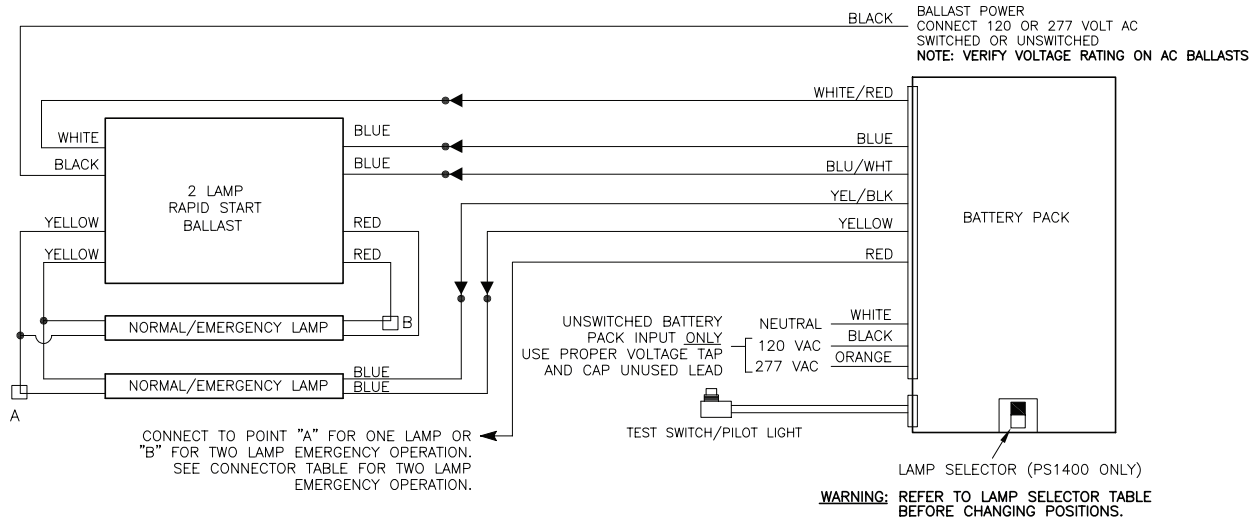

FIGURE B

ONE LAMP INSTANT START SLIMLINE BALLAST

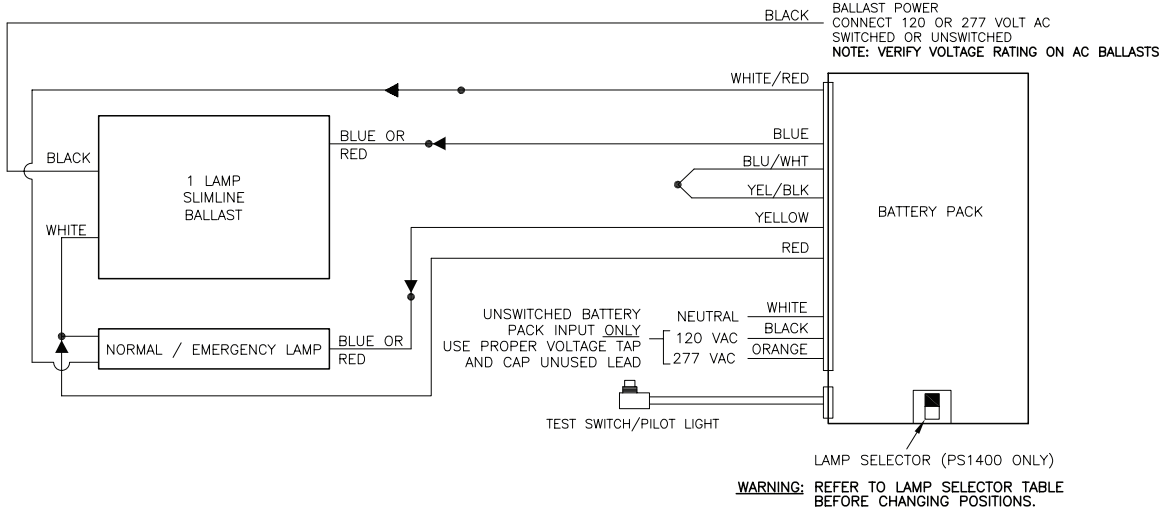

FIGURE C

TWO LAMP LEAD/LAG INSTANT START SLIMLINE BALLAST

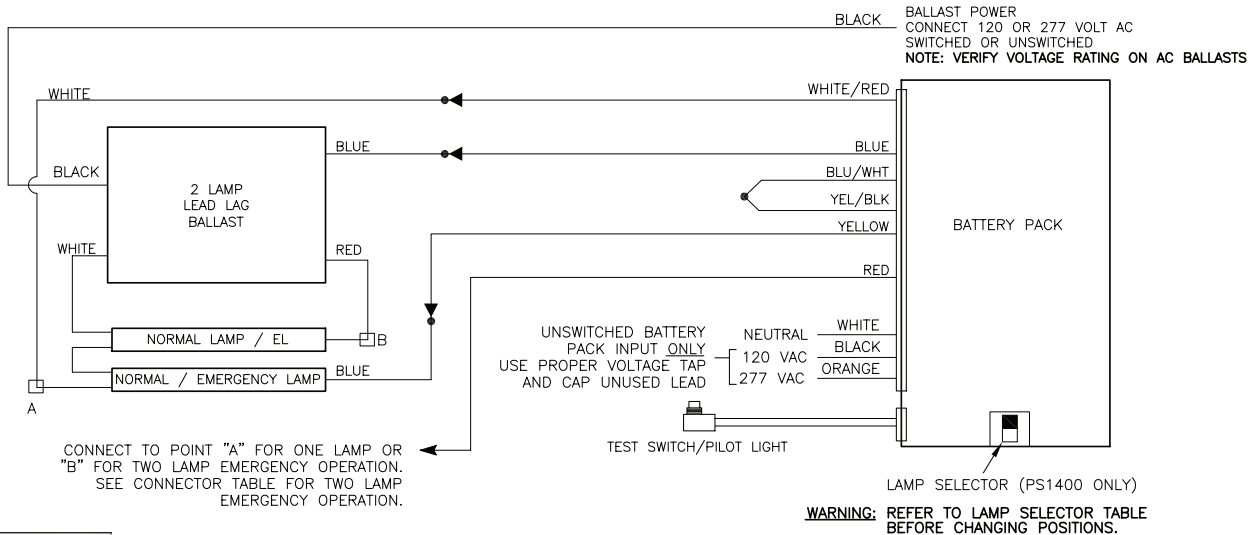

FIGURE D
Page 5

TWO LAMP SERIES LEAD BALLAST

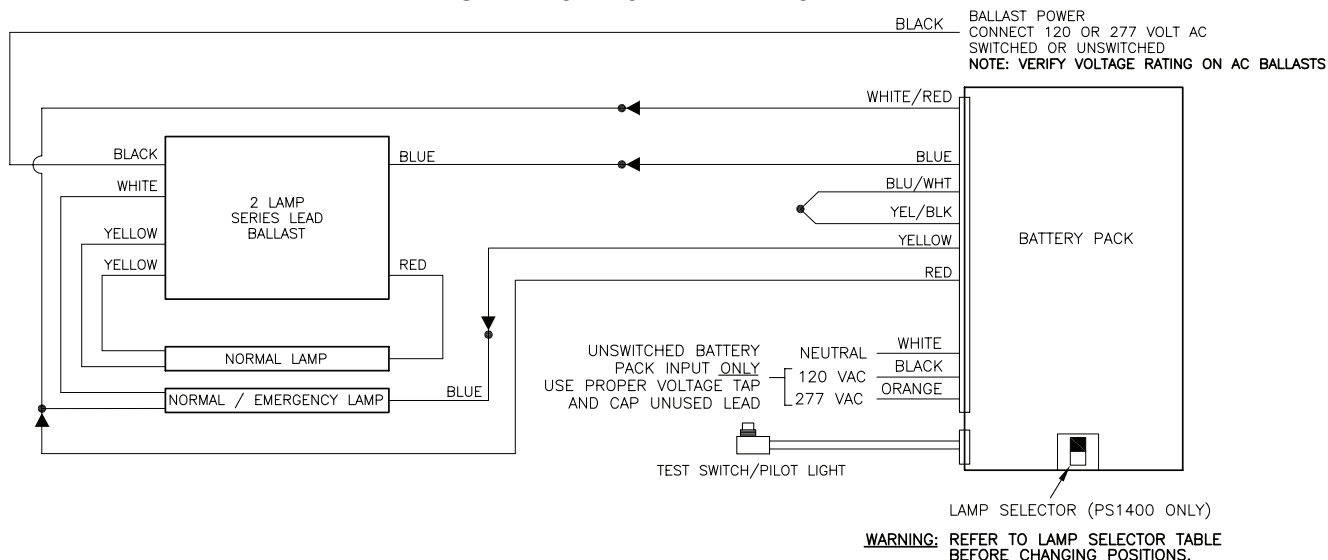

FIGURE E

TWO LAMP INSTANT START BALLAST

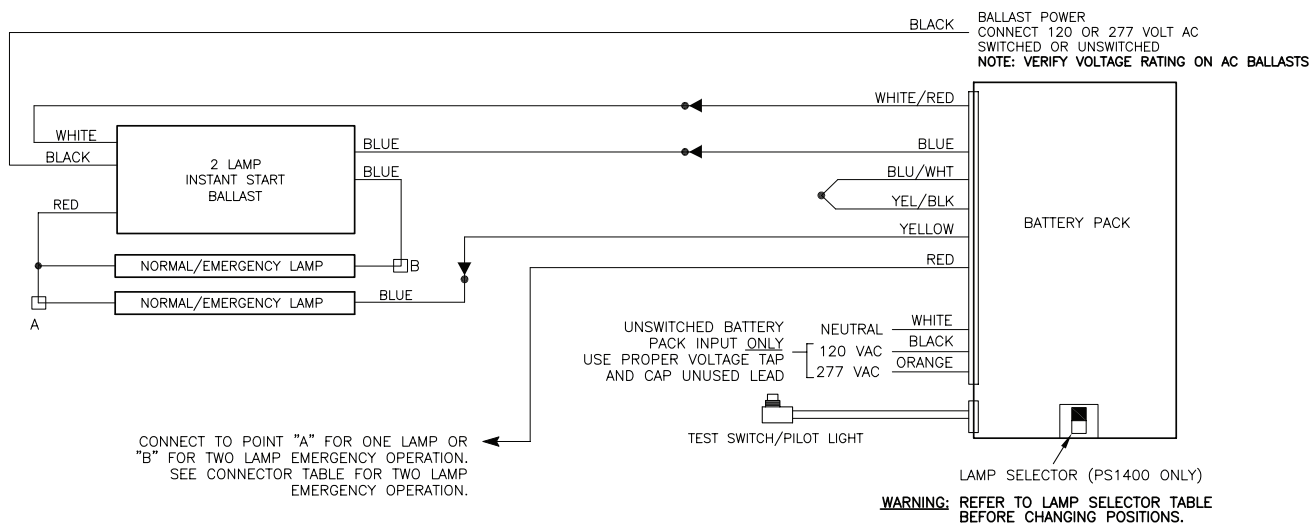

FIGURE F

THREE LAMP RAPID START BALLAST

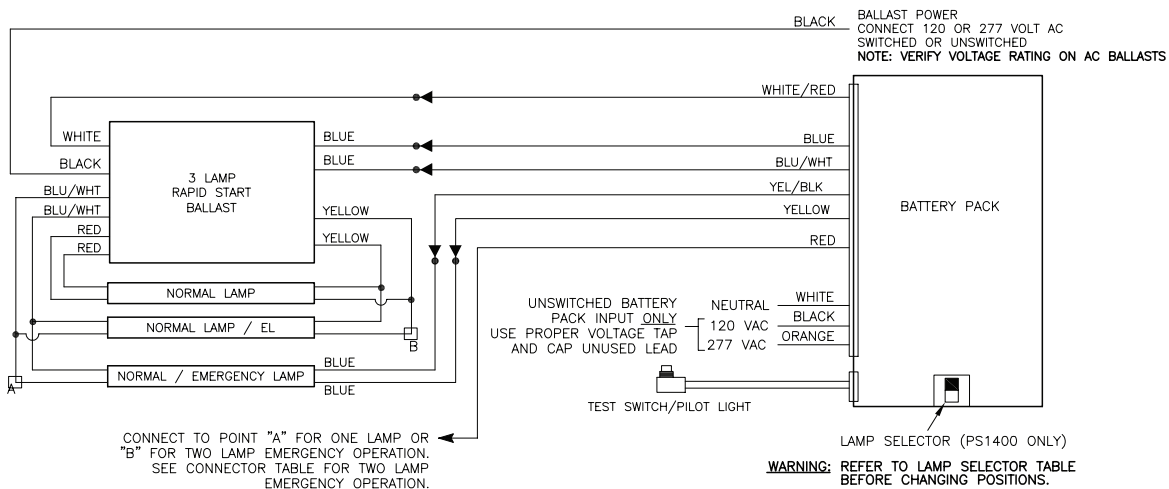

FIGURE G
Page 6

THREE LAMP INSTANT START BALLAST

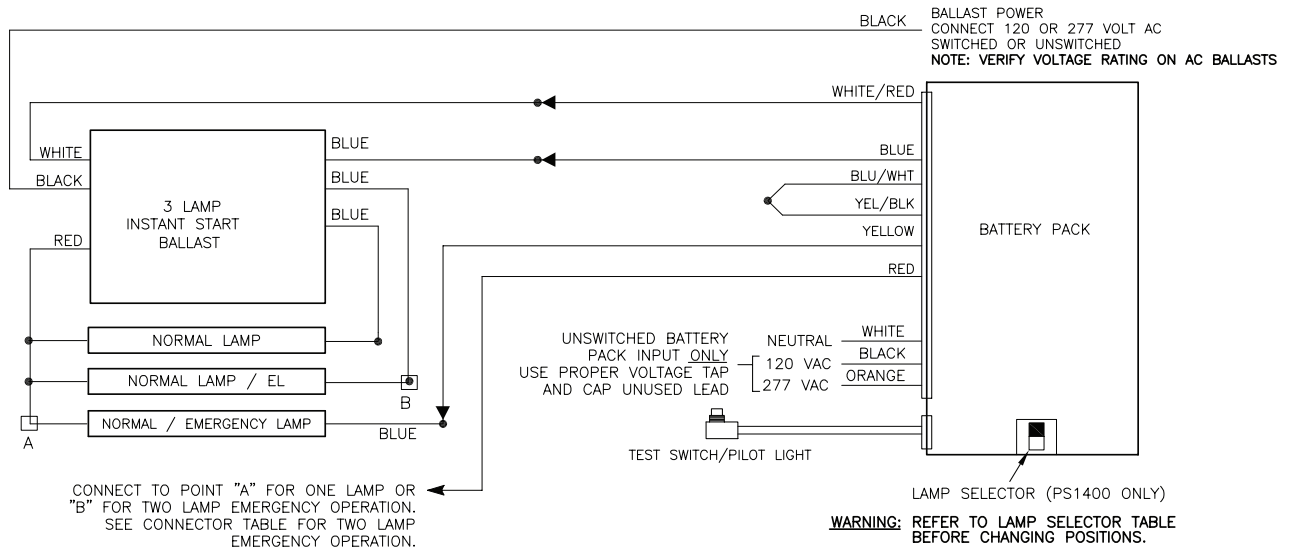

FIGURE H

ONE LAMP WITHOUT AC BALLAST

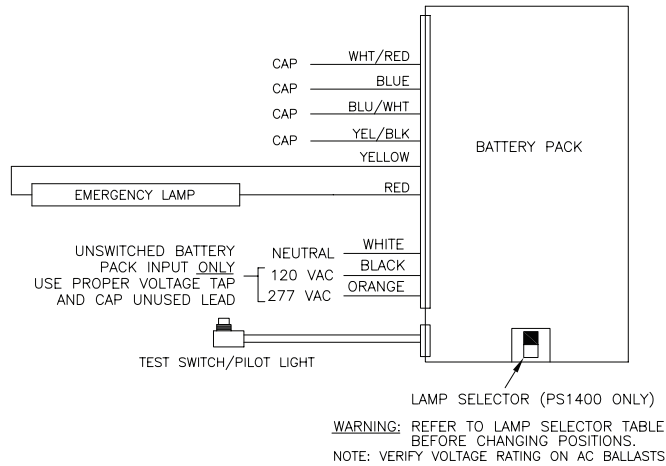

FIGURE I

TWO LAMP WITHOUT AC BALLAST

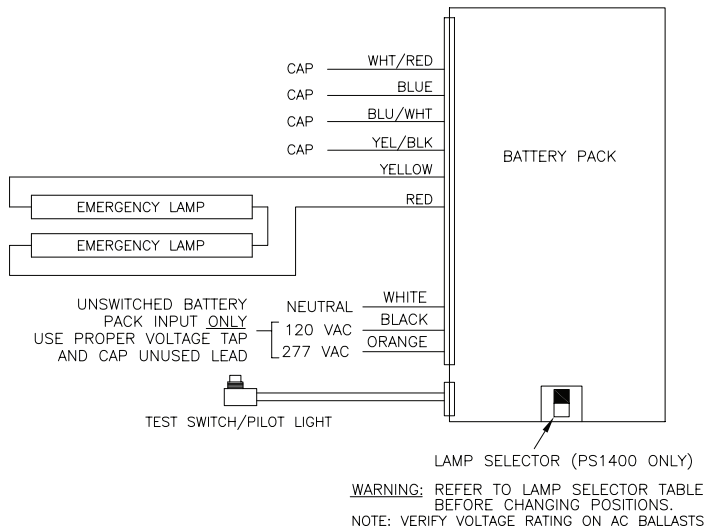

FIGURE J

ONE LAMP INSTANT START BALLAST

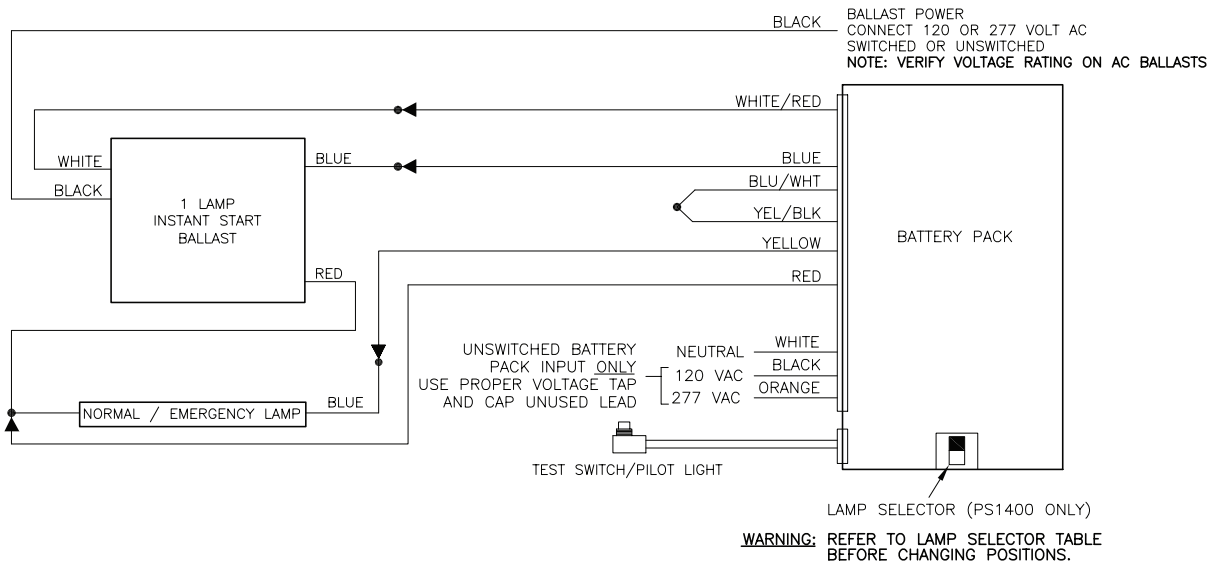

FIGURE K

ONE LAMP CIRCLINE BALLAST

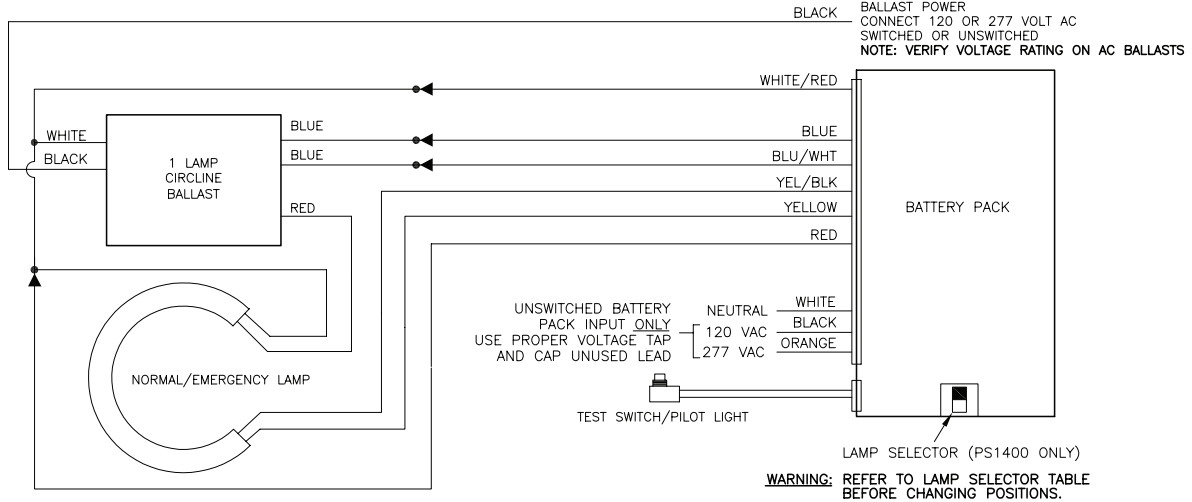

FIGURE L

TWO LAMP CIRCLINE BALLAST

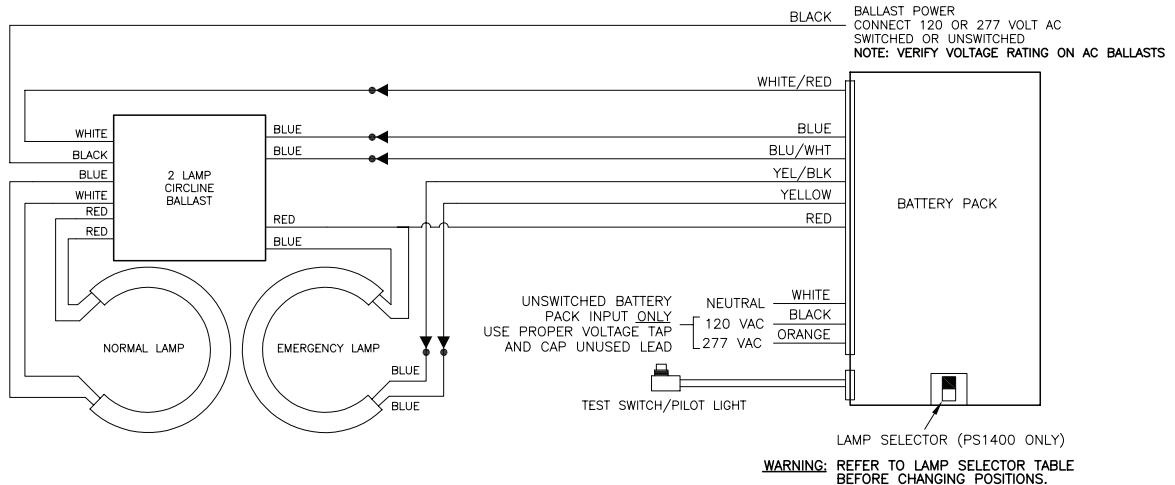

FIGURE M

FOUR LAMP INSTANT START ELECTRONIC BALLAST

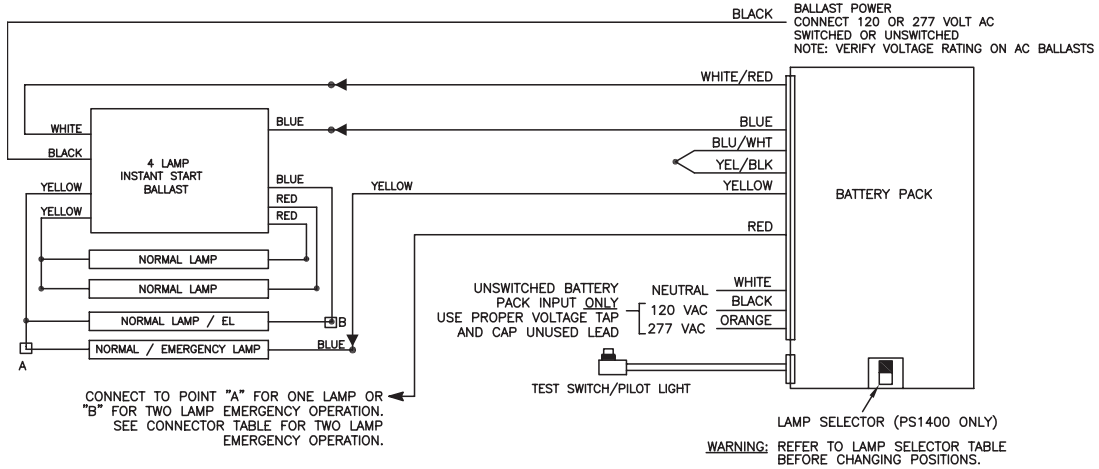

FIGURE N

TWO LAMP SERIES SEQUENCE INSTANT START BALLAST

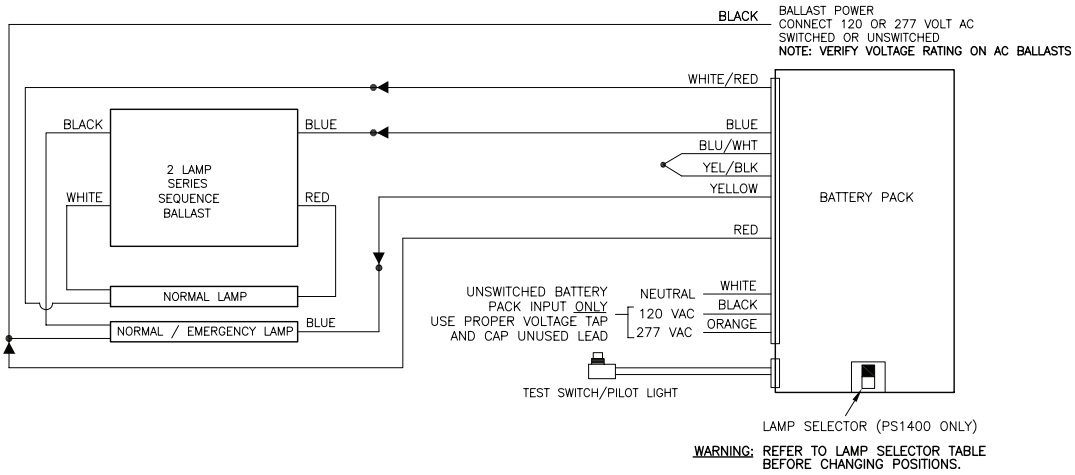

FIGURE O

ONE FOUR-PIN COMPACT LAMP RAPID START BALLAST (PS1400 ONLY)

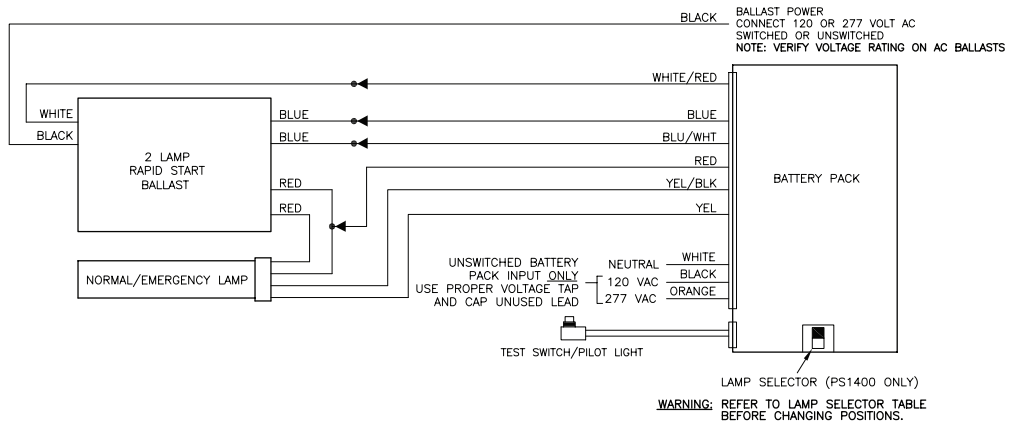

FIGURE P

TWO FOUR-PIN COMPACT LAMP RAPID START BALLAST (PS1400 ONLY)

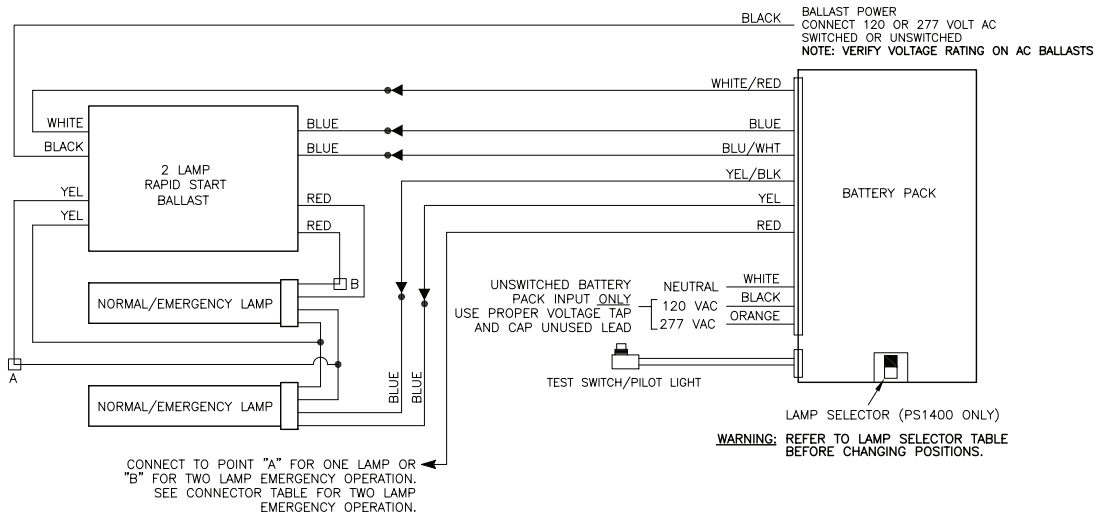

FIGURE Q

FOUR LAMP RAPID START BALLAST

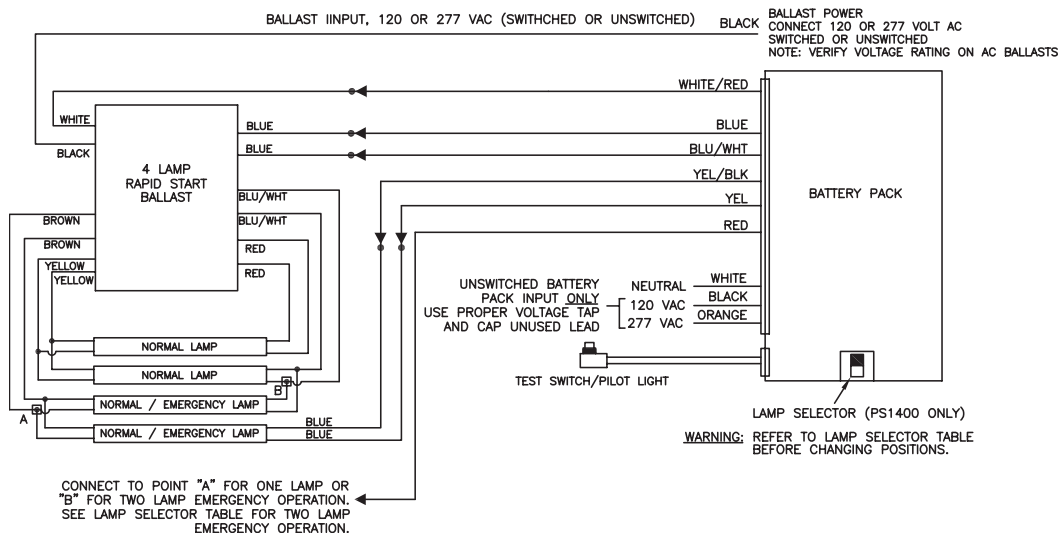

FIGURE R

PS300 AND PSQ500 WARRANTY THREE-YEAR TOTAL CUSTOMER SATISFACTION

Complete Customer Satisfaction. This unit is guaranteed to perform to our customers' complete satisfaction for a period of three years from date of invoice. Our guarantee liability extends only to the repair or replacement of the defective part, and no labor charges for correction of the defect by repair or replacement will be paid by Lithonia unless prior written authority has been granted by our Post-Sales Department.

PS600 AND PS1400 WARRANTY FIVE-YEAR TOTAL CUSTOMER SATISFACTION

Complete Customer Satisfaction. This unit is guaranteed to perform to our customers' complete satisfaction for a period of five years from date of invoice. Our guarantee liability extends only to the repair or replacement of the defective part, and no labor charges for correction of the defect by repair or replacement will be paid by Lithonia unless prior written authority has been granted by our Post-Sales Department.



www.powersentrysafety.com

1-888-300-7017

Page 10

Partno. EMCSA00726

REV H