

## Cleaning and Maintenance:

1. Unplug the pump and disconnect it from the 1/2" fill fitting. Remove it from the MegaGarden system and place it in a bucket or to the side for cleaning.
2. Drain the entire reservoir using the view/drain tube assembly.
3. Rinse the reservoir, propagation tray, and pump using a high pressure spray nozzle. A scouring pad might be necessary to remove nutrient salt build up from the plastic.
4. After all the components have been thoroughly rinsed, re-assemble the MegaGarden and pump assembly.

## Sterilization (Optional):

5. Fill the reservoir up with a mixture of H2O2 (hydrogen peroxide) and water. Dilute at a rate of 1oz. per gallon of water.
6. Turn the pump on once the reservoir is completely full. Allow it to run for approximately 30 minutes to completely disinfect the pump and components.
7. Drain the solution and rinse all the parts thoroughly.

## Special Notes and Instructions:

- Rockwool cubes should be treated prior to use. Run plenty of fresh water through them and soak them in a 5.5 pH solution.
- For best results, seed germination should be done prior to operation of the MegaGarden. A Germination Station (CK64050) or Hot House (64060) will assist in successful seed germination from which seedlings can be transplanted into the MegaGarden to initiate the growth cycle.
- Once a healthy root mass is established from the seedling or cutting, plant the starter cube so the top of it is approximately 1.5" deep in the planter.
- Maintain a pH value of 5.5 to 6.0 in the nutrient solution for maximum uptake.
- A water temperature of 65 to 70 degrees Fahrenheit is ideal for the root zone.
- Watering cycles are automated by the timer included in the package. Approximately 1 to 4 feedings per day is acceptable for most stages of crop development.

- Running air stones in the reservoir will increase the available levels of oxygen and promote a healthier garden.
- When using a new nutrient system, start off at 25-50% of the recommended dilution rate opposed to full strength. Ex. If the bottle calls for 15 ml per gallon, start with 5 ml per gallon.
- Empty the reservoir completely and fill it with fresh solution at least once every 14 days.
- Other grow mediums such as rockwool blocks, silica stone, PET-1, perlite, and other soilless hydroponic substrates are approved for use in the MegaGarden.

## Lighting

The more light you give your plants, the faster they will grow considering that other grow room conditions are ideal. If your growing season is short with cold temperatures, it's best to give your plants an early start indoors under our T-5 lighting systems or Agrosun fluorescents.

Line the entire growing area with a white surface or material to reflect the maximum amount of light. Metallized film or white plastic are recommended. Flat white paint also works very well. A heavy duty grounded timer will make the light cycle automatic.

## Temperature and air circulation

Most plants prefer temperatures between 65 and 90 degrees Fahrenheit. 70-80 degrees is closer to the optimum. Humidity should not be below 45 percent or above 80 percent. Using an oscillating fan will help keep temperatures down when it's too hot, strengthen the plants, and bring in fresh air if you're growing in an enclosed area. Don't blow them over, but give them a gentle breeze for part of the day to promote air circulation. Monitor the water temperature and avoid excessive heat to build in the root zone as this could damage the plants.

## Harvest

Harvest time is very near when the herbs or vegetables are almost fully ripened and are changing color. Harvest the crop by cutting off the ripened produce.

- Inspect carefully for any insects, fungus or mold. If you discover signs of these, consult your indoor garden supply store for pest control methods.
- Any fungicides or insecticides should be used at 10% - 15% the normal rate.
- If you have used any new product that seems to have an adverse affect on your system, flush the system.

## PROBLEMS AND TROUBLESHOOTING

The most common sources of problems result from over watering, nutrient overdose, insufficient lighting, and extreme temperatures. Re-check your procedures and conditions to make sure you have followed all the directions correctly

- If the plants show signs of tip burning, flush system with fresh water, and cut back the strength of the nutrients.
- If the inflow tube is not flowing freely, check the intake on the pump.

## The Hydrofarm Guarantee

The MegaGarden electrical components are guaranteed to the original owner for 1 year from the date of purchase. Misuse, abuse, or failure to follow instructions is not covered. If you have a problem, recheck your system and pump. If this does not remedy the situation, contact the original place of purchase for a warranty assessment. Unauthorized returns will not be accepted. Save your receipt/invoice – a copy is required for all warranty work.



# MegaGarden

## Congratulations on the purchase of a Hydrofarm Megagarden system —

The MegaGarden is a high performance hydroponic growing system designed with simplicity in mind. Anyone from the novice to the professional green thumb can use the MegaGarden with ease and get fantastic results. This exclusive Hydrofarm design is compact yet very productive, implementing automated flood & drain (ebb & flow) technology, and using less water to grow more produce. Crops grown in the MegaGarden experience dramatic growth rates as the roots are directly fed with oxygenated nutrient solution, versus conventional soil gardening which requires the roots to search for food sources in the dirt. With the assistance of a Hydrofarm grow light system such as the Sunburst or a T5 fluorescent, the MegaGarden can provide year-round production for all your gardening desires!

## HYDROPONICS: SIMPLE, QUICK AND EASY

Hydroponics is simply a more efficient way to provide nutrition and water to your plants. In a soil garden nutrients and water are randomly scattered about throughout the medium, and plants have to expend a lot of energy growing roots to find them. In a hydroponic garden the nutrients and water are delivered directly to your plants' roots by pumping solution on timed cycles. Your plants can grow quicker and can be harvested sooner because they are absorbing nutrition at a faster rate.

## MEGAGARDEN PARTS LIST:

Parts:			
Reservoir (8 GAL)	x 1	View/Drain tube assembly	x 1
Propagation tray with holes	x 1	Red porthole cap	x 1
Hydrofarm planters	x 15	Drain hole filters	x 2
Clay Pebble Growing Media 25L bag (included with some models)	x 1	Tray support column	x 1
Clay Pebble Growing Media 5L bag (included with some models)	x 1	Active Aqua submersible pump	x1
Flood & Drain assembly:		1/2" inflow tube	x 1
a. 1/2" fill fitting	x 1	Nutrient sample pack	x 1
b. 3/4" drain fitting	x 1	Hydrofarm timer	x 1
c. 3/4" riser	x 1	pH Test Kit	x 1
d. 1 1/4" riser	x 1	Starter cubes	x24
e. Drain screens	x 2		

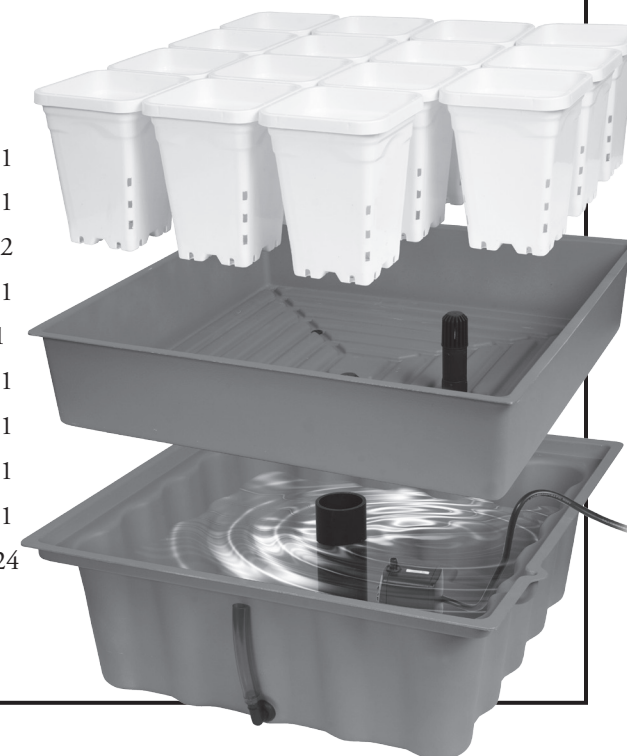

**Assembly Instructions:**

1. Remove all of the MegaGarden components from the packaging and ensure everything is accounted for by referencing from the **PARTS** list.

**View tube Installation: Figure A.**

1. Remove the grommet from the view tube assembly elbow.
2. Install the grommet into the lower hole on the reservoir.
3. Re-insert the view tube drain elbow securely into the grommet.

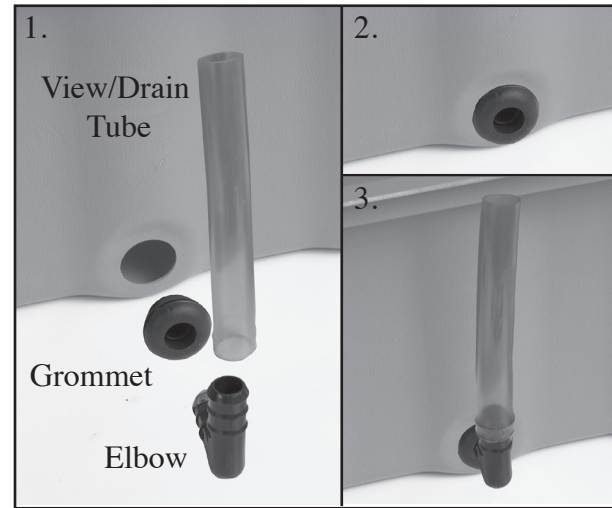

**Figure A.**

**Support Column:**

1. Place the support column over the round mold in the bottom center of the reservoir, see **Figure B.**



**Figure B.**

**Flood & Drain Installation:**

1. To install the fill and drain fittings remove the threaded nuts and rubber washer from each fill/drain fitting.

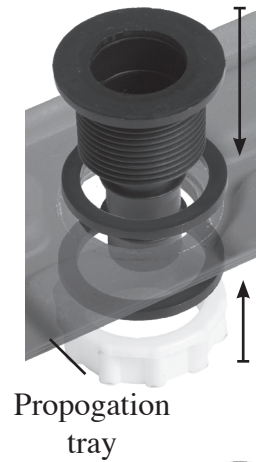

2. Insert both fittings through the top of the propagation tray into the two pre-cut holes. Replace rubber washer and threaded nut to each fitting from below. The tray should be wedged between the two rubber washers on each drain fitting to prevent leaking, and secured into place with the threaded nut on the bottom.

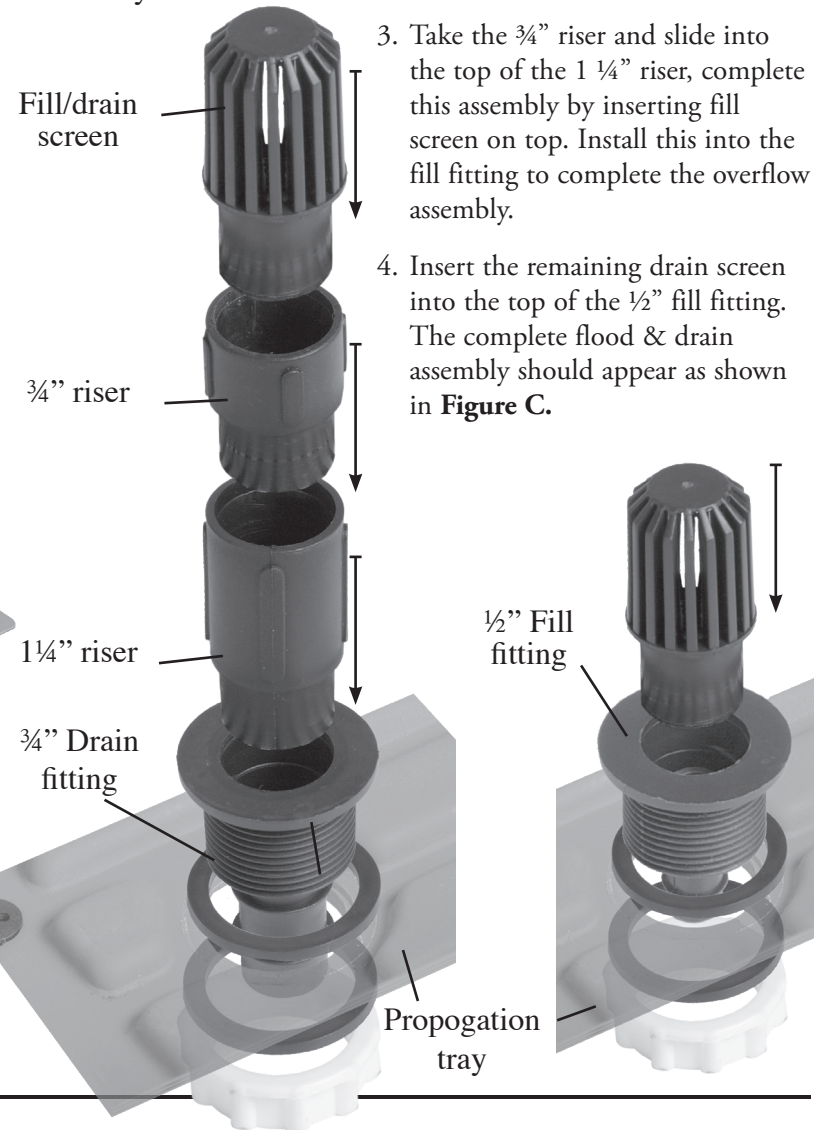

3. Take the 3/4" riser and slide into the top of the 1 1/4" riser, complete this assembly by inserting fill screen on top. Install this into the fill fitting to complete the overflow assembly.
4. Insert the remaining drain screen into the top of the 1/2" fill fitting. The complete flood & drain assembly should appear as shown in **Figure C.**

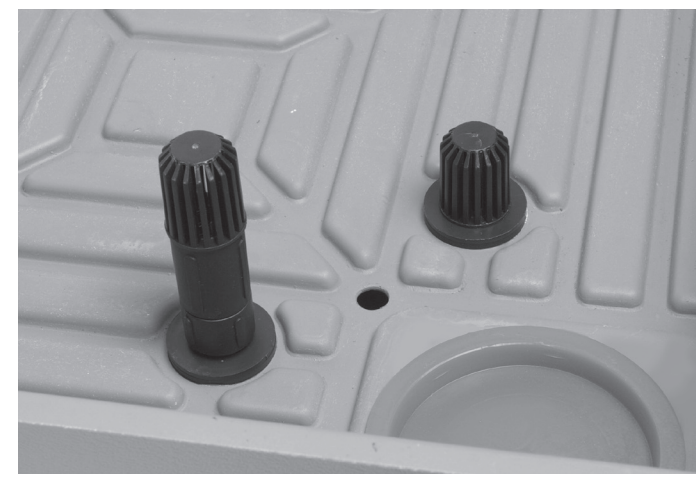

**Figure C.**

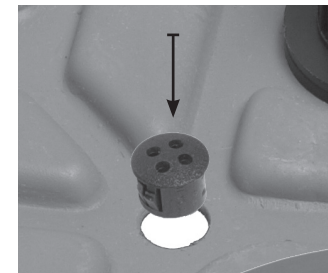

**Figure D.**



**Figure E.**

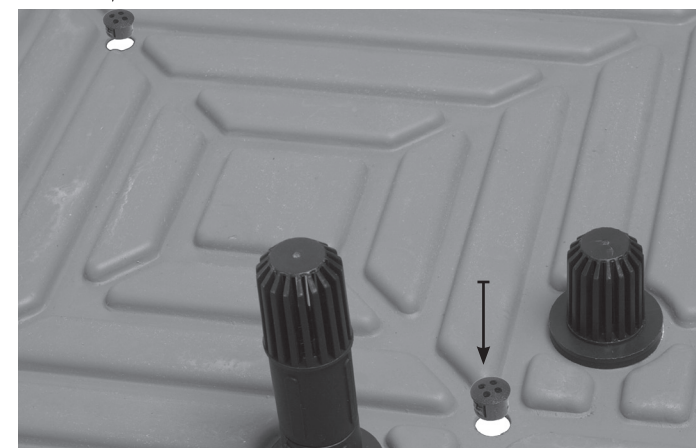

**Figure F.**

**Warnings:**

Keep the overflow screen and drain hole filters free of debris to prevent overflow of the propagation tray.

**Pump & Tube Assembly:**

1. Remove the submersible pump and additional 1/2" fitting from the box.

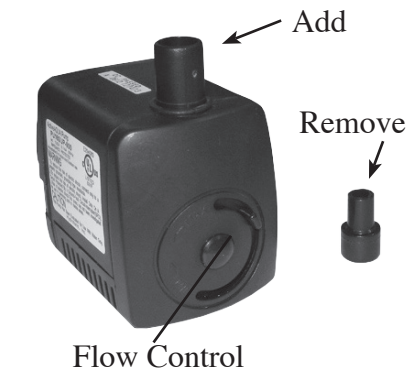

**Figure G**

2. The 3/8" fitting that comes pre-installed on the pump needs to be replaced with the 1/2" one. Carefully clamp onto the outlet and pull the fitting out of the pump. The fit is snug, but it can be removed. Take care not to break it if pliers are used for the removal, see **Figure G.**

3. The slider located on the pump (**Figure G**) dictates the water projection rate. We recommend a faster fill rate opposed to a slower one, but this is optional and customizable to suit your needs.

1/2" black tube



4. Carefully attach the pump to the 1/2" fill fitting installed in the propagation tray using the piece of 1/2" black tube. **Figure H.**



**Figure H**

5. Place the propagation tray on top of the reservoir making sure the PVC support column is in place.

**Note: DO NOT connect the pump to the power supply unless it is fully submerged in solution. Failure to do so may cause permanent damage to the pump.**

\* For a more precise reading, ask your local Hydrofarm dealer about digital nutrient testers.