



ODS10-IDT

Description

800W@120V INC 1200VA@120V 2700VA@277V FL, 120/277 Volt AC 60Hz, Single-Pole, 180 Degree, 2100 Sq. Ft. Coverage, Decora Passive Infrared Wall Switch Occupancy Sensor, Commercial Grade - Light Almond.

Product Features

Color: Light Almond



Switch Type: Single-Pole

Adjustment: Manual

Technology: Passive Infrared

Pattern Degrees: 180

Coverage Range Sq. Ft.: 2100

Time Adjustment: 30s-20m

Load Rating: 800W@120V INC 1200VA@120V
2700VA@277V FL

Voltage: 120/277 Volt AC 60Hz

Wiring Neutral / Ground: Ground Required

Photo Cell: Ambient Override ON

Wallplate: Order Separately

Color: Light Almond

Standards and Certifications: UL/cUL

Warranty: 5-Year Limited

Code Compliance: California Title 24

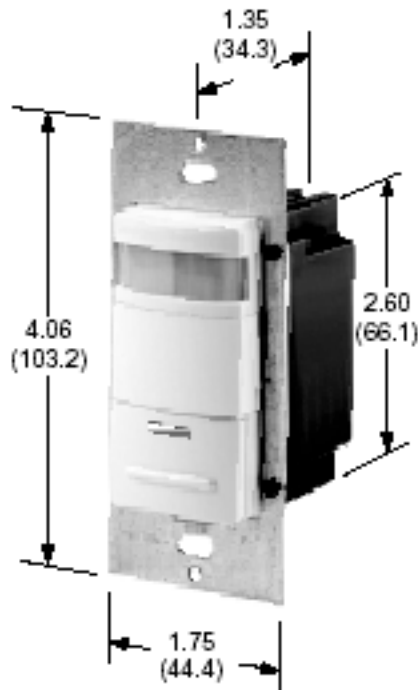

SPECIFICATION SUBMITTAL

JOB NAME: <input type="text"/>	CATALOG NUMBERS: <input type="text"/>	
JOB NUMBER: <input type="text"/>	<input type="text"/>	<input type="text"/>

Leviton Manufacturing Co., Inc.

201 North Service Road, Melville, NY 11747

Telephone: 1-800-323-8920 · FAX: 1-800-832-9538 · Tech Line (8:30AM-7:30PM E.S.T. Monday-Friday): 1-800-824-3005

Leviton Manufacturing of Canada, Ltd.

165 Hymus Boulevard, Pointe Claire, Quebec H9R 1E9 · Telephone: 1-800-469-7890 ·

FAX: 1-800-824-3005 · www.leviton.com/canada

Leviton S. de R.L. de C.V.

Lago Tana 43, Mexico DF, Mexico CP 11290 · Tel.: (+52)55-5082-1040 · FAX: (+52)5386-1797 · www.leviton.com.mx



Visit our Website at: www.leviton.com

© 2007-2009 Leviton Manufacturing Co., Inc. All rights reserved. Subject to change without notice.

Leviton has a global presence.

If you would like to know where your local Leviton office is located please go to:

www.leviton.com/international/contacts/