

MasterColor® Ceramic Metal Halide 150 Watt Double-Ended TD-7 3K Lamp

with FadeBlock™

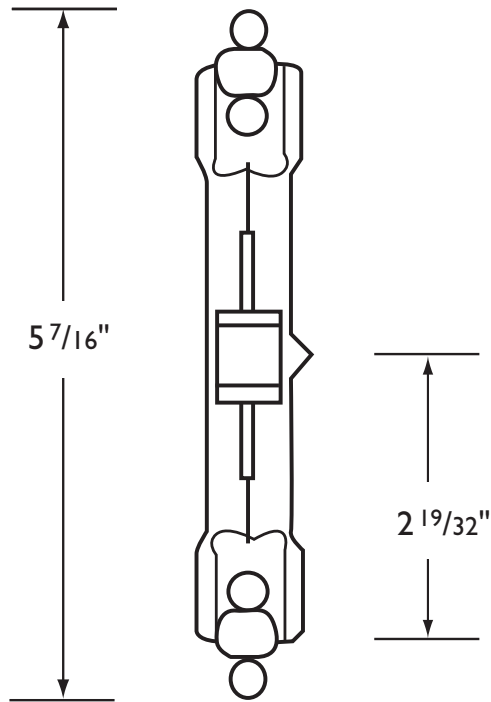

■ Ordering Information

Ordering Code	CDMI50/TD/830
ANSI Designation	M142/M102/M81/E
Product Number	231670
Description	MasterColor Ceramic Metal Halide
Package Quantity	12

■ Physical Characteristics

Bulb Size	TD-7
Bulb Finish	Clear
Base	RX7s
Max. Overall Length (MOL)	5 7/16" (137mm)
Light Center Length (LCL)	2 19/32" (66mm)
Arc Length	0.394" (10mm)
Arc Tube Material	Polycrystalline Alumina
Max. Permissible Bulb Temperature	650°C (1202°F)
Max. Permissible Base Temperature	300°C (572°F)
Max. Bulb to Base Eccentricity	3°
Max. Arc Tube to Base Eccentricity	3°

■ Operating Characteristics (Photometric)

Rated Initial Lumens ⁽¹⁾	13,250
Mean Lumens, Approx. ⁽²⁾	11,260
Rated Average Life, Hours	15,000
Correlated Color Temp. (CCT) ⁽²⁾	3000 K
CIE Chromaticity Approx. ⁽²⁾	x-.431, y-.390
Color Rendering Index (CRI)	88
Efficacy (lpw)	90

■ Operating Position

Horizontal ± 45°—Enclosed Luminaires Only

Note: Electronic ballasts are preferred for optimum performance, energy efficiency and circuit loading.

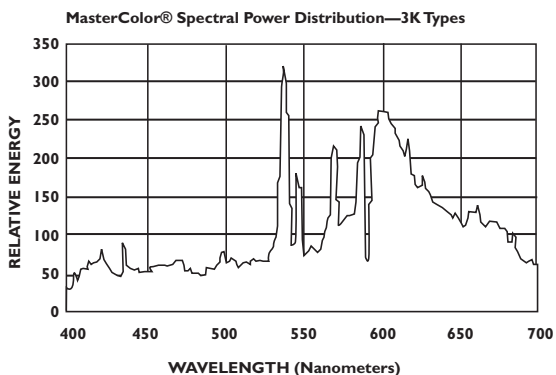

PHILIPS

Philips Lighting Company
200 Franklin Square Drive ■ P.O. Box 6800
Somerset, NJ 08875-6800
1-800-555-0050

www.lighting.philips.com/nam

A Division of Philips Electronics North America Corporation

Printed in USA 6/04

CDM 008

Philips Lighting
281 Hillmount Road
Markham, Ontario
Canada L6C 2S3
1-800-555-0050
www.lighting.philips.com/nam
A Division of Philips Electronics Ltd.

MasterColor® Ceramic Metal Halide 150 Watt Double-Ended TD-7 3K Lamp with FadeBlock™

Electrical Data (Subject to change without notice)

Lamp Watts (Nominal)	150
Lamp Operating Voltage (rms) (Nominal) ⁽²⁾	96
Initial Lamp Voltage Range (rms) ⁽³⁾	85-105
Lamp Operating Current (Amps) (rms) (Nominal)	1.8
Lamp Current Crest Factor (Maximum)	1.8
Warm-up Time to 80% of Output	2 Minutes
Re-strike Time for Hot Lamp	4-8 Minutes
Ballast Type	ANSI M142
Ballast Open Circuit Voltage (Minimum)	198
Pulse Peak Volts	3000 Min., 4000 Max.
Pulse Width @ 90% Peak	2 Micro Second Minimum
Pulse Repetition Rate (Minimum)	2 per Half Cycle
Minimum Operating Temperature	-30°C

(1) Measured at 100 hrs of life in horizontal position.

(2) Measured at rated lamp watts on a linear reactor. LPW does not include ballast losses.

(3) Measured with the lamp operating at rated watts.

INSTALLATION INFORMATION

MasterColor® Metal Halide TD-7 lamps must be used in combination with appropriate ballast and ignitor or suitable full electronic ballast. For satisfactory operation of the lamp, the supply voltage should not fluctuate more than $\pm 5\%$ from the rated voltage of the ballast ($\pm 10\%$ for electronic ballast).

WARNINGS, CAUTIONS AND OPERATING INSTRUCTIONS

R“WARNING: These lamps can cause serious skin burn and eye inflammation from short wave ultraviolet radiation if outer envelope of the lamp is broken or punctured. Do not use where people will remain for more than a few minutes unless adequate shielding or other safety precautions are used. Certain lamps that will automatically extinguish when the outer envelope is broken or punctured are commercially available.” This lamp complies with FDA radiation performance standard 21 CFR subchapter J. (USA: 21 CFR 1040.30 Canada: SOR/DORS/80-381)

If the outer bulb is broken or punctured, turn off at once and replace the lamp to avoid possible injury from hazardous short wave ultraviolet radiation. Do not scratch the outer bulb or subject it to pressure as this could cause the outer bulb to crack or shatter. A partial vacuum in the outer bulb may cause glass to fly if the envelope is struck.

WARNING: The arc-tube of metal halide lamps are designed to operate under high pressure and at temperatures up to 1000° C and can unexpectedly rupture due to internal or external factors such as a ballast failure or misapplication. If the arc-tube ruptures for any reason, the outer bulb may break and pieces of extremely hot glass might be discharged into the surrounding environment. If such a rupture were to happen, **THERE IS A RISK OF PERSONAL INJURY, PROPERTY DAMAGE, BURNS AND FIRE.**

Certain lamps that will retain all the glass particles should inner arc-tube rupture occur are commercially available from Philips Lighting Company.

RELAMP FIXTURES AT OR BEFORE THE END OF RATED LIFE. Allowing lamps to operate until they fail is not advised and may increase the possibility of inner arc tube rupture.

This lamp contains an arc tube with a filling gas containing Kr-85 and is distributed by Philips Lighting Company, a division of Philips Electronics North America Corporation, Somerset, New Jersey, 08875.

CAUTION: TO REDUCE THE RISK OF PERSONAL INJURY, PROPERTY DAMAGE, BURNS AND FIRE RESULTING FROM AN ARC-TUBE RUPTURE THE FOLLOWING **LAMP OPERATING INSTRUCTIONS** MUST BE FOLLOWED:

LAMP OPERATING INSTRUCTIONS:

1. RELAMP FIXTURES AT OR BEFORE THE END OF RATED LIFE. Allowing lamps to operate until they fail is not advised and may increase the possibility of inner arc tube rupture.
2. Use only in fully enclosed fixtures capable of withstanding particles of glass having temperatures up to 1000° C. Lens/diffuser material must be heat resistant. Consult fixture manufacturer regarding the suitability of the fixture for this lamp.
3. Do not operate a fixture with a missing or broken lens/diffuser.
4. Operate lamp only within specified limits of operating position.
5. Before lamp installation/replacement, shut power off and allow lamp and fixture to cool to avoid electrical shock and potential burn hazards.
6. Use only auxiliary equipment meeting Philips and/or ANSI standards. Use within voltage limits recommended by ballast manufacturer.
 - A. Operate lamp only within specified limits of operation.
 - B. For total supply load refer to ballast manufacturers electrical data.
- C. Operate CDM-T (G12 base) and CDM-TC (G8.5 base) lamps only on thermally protected ballasts.**
- D. Operate CDM-TC lamps (G8.5 base) only on electronic ballasts.**
7. Periodically inspect the outer envelope. Replace any lamps that show scratches, cracks or damage.
8. If a lamp bulb support is used, be sure to insulate the support electrically to avoid possible decomposition of the bulb glass.
9. Protect lamp base, socket and wiring against moisture, corrosive atmospheres and excessive heat.
10. Time should be allowed for lamps to stabilize in color when turned on for the first time. This may require several hours of operation, with more than one start. Lamp color is also subject to change under conditions of excess vibration or shock and color appearance may vary between individual lamps.
11. Lamps may require 4 to 8 minutes to re-light if there is a power interruption.
12. Take care in handling and disposing of lamps. If an arc tube is broken, avoid skin contact with any of the contents or fragments.

