

Energy Advantage CDM with AllStart Technology

330 Watt 4000K ED28 (Clear) Lamp

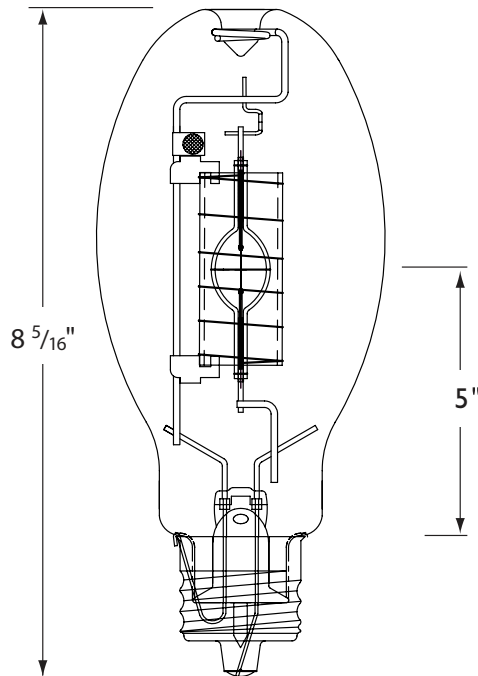

Ordering Information

Ordering Code	CDM330/U/O/4K/ED28
	EA Allstart
ANSI Designation	C185/O
Product Number	411058
Description	Ceramic Metal Halide
Package Quantity	12

Physical Characteristics

Bulb Size	ED-28
Bulb Finish	Clear
Base	Extended Eyelet Mogul Screw (EX39)
Max. Overall Length (MOL)	8 5/16" (211mm)
Light Center Length (LCL)	5" (127mm)
Arc Tube Material	Ceramic (PCA)
Max. Permissible Bulb/Shroud Temp.	400°C (752°F)
Max. Permissible Base/Collar Temp.	210°C (410°F)
Max. Bulb to Base Eccentricity	3°
Max. Arc Tube to Base Eccentricity	3°

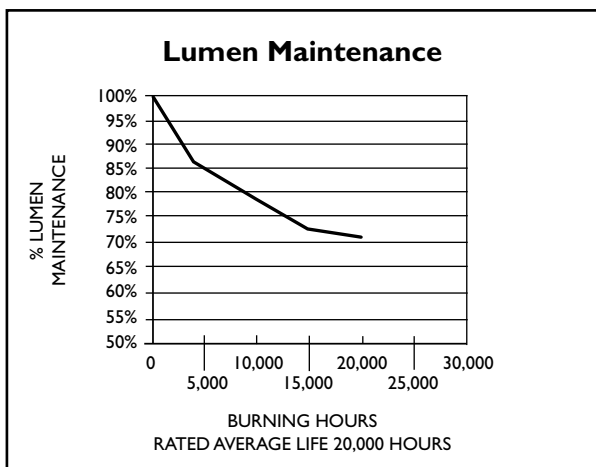

Operating Characteristics (Photometric)

Rated Initial Lumens ¹	33,000
Mean Lumens, Approx. ²	26,400
Rated Average Life, Hours ³	20,000
Correlated Color Temp. (CCT)	4000K
CIE Chromaticity Approx.	x-.384, y-.378
Color Rendering Index (CRI)	90
R9	50

Operating Position

Universal — Open or Enclosed Luminaires

PHILIPS

Energy Advantage CDM with AllStart Technology (Clear) Lamp

Electrical Data (Subject to change without notice)

Lamp Watts (Nominal)	330 Watts
Lamp Operating Voltage (rms) (Nominal) ⁴	125V
Initial Lamp Voltage Range (rms) ⁵	115 – 135V
Lamp Operating Current (Amps) (rms) (Nominal)	3.02A
Warm-up Time to 80% of Output	< 5 Minutes
Re-strike Time for Hot Lamp	< 12 minutes for Probe Start ballasts, < 7 minutes for Pulse Start ballasts
Ballast Type	Magnetic Ballasts ANSI M59/M165/M128/M135/M155/M172/C185/O
Ballast Open Circuit Voltage (Minimum)	Probe Start Ballasts: Peak Lead: 280V (with VCF=1.8) and Reactor: 350V Pulse Start ballasts (peak lead or Reactor): 254V
Minimum Operating Temperature	-30°C

1) Measured at 100 hrs of life in vertical position.

2) Approximate lumen output at 40% of lamp rated average life.

3) Rated average life is obtained at 50% survival rate.

4) Measured at rated lamp watts on a linear reactor. LPW does not include ballast losses.

5) Measured with the lamp operating at rated watts.

Warnings, Cautions and Operating Instructions for Protected Energy Advantage Ceramic Metal Halide with AllStart™ Technology

R“**WARNING:** These lamps can cause serious skin burn and eye inflammation from short wave ultraviolet radiation if outer envelope of the lamp is broken or punctured. Do not use where people will remain for more than a few minutes unless adequate shielding or other safety precautions are used. Certain lamps that will automatically extinguish when the outer envelope is broken or punctured are commercially available.” This lamp complies with FDA radiation performance standard 21 CFR subchapter J. (USA:21 CFR 1040.30 Canada:SOR/DORS/80-381)

If the outer bulb is broken or punctured, turn off at once and replace the lamp to avoid possible injury from hazardous short wave ultraviolet radiation. Do not scratch the outer bulb or subject it to pressure as this could cause the outer bulb to crack or shatter. A partial vacuum in the outer bulb may cause glass to fly if the envelope is struck.

WARNING: The arc-tube of metal halide lamps are designed to operate under high pressure and at temperatures up to 1000°C and can unexpectedly rupture due to internal or external factors such as a ballast failure or misapplication. If the arc-tube ruptures for any reason, the outer bulb may break and pieces of extremely hot glass might be discharged into the surrounding environment. If such a rupture were to happen, **THERE IS A RISK OF PERSONAL INJURY, PROPERTY DAMAGE, BURNS AND FIRE.**

These lamps are designed to retain all the glass particles should an arc tube rupture occur. The following operating instructions are recommended to minimize these occurrences.

RELAMP FIXTURES AT OR BEFORE THE END OF RATED LIFE.
Allowing lamps to operate until they fail is not advised and may increase the possibility of inner arc tube rupture.

This lamp contains an arc tube with a filling gas containing less than 65 nCi Kr-85 and is distributed by Philips Lighting Company, a division of Philips Electronics North America Corporation, Somerset, New Jersey, 08873.

CAUTION: TO REDUCE THE RISK OF PERSONAL INJURY, PROPERTY DAMAGE, BURNS AND FIRE RESULTING FROM AN ARC-TUBE RUPTURE THE FOLLOWING LAMP OPERATING INSTRUCTIONS MUST BE FOLLOWED:

LAMP OPERATING INSTRUCTIONS:

1. RELAMP FIXTURES AT OR BEFORE THE END OF RATED LIFE.
Allowing lamps to operate until they fail is not advised and may increase the possibility of inner arc tube rupture.
2. Before lamp installation/replacement, shut power off and allow lamp and fixture to cool to avoid electrical shock and potential burn hazards.
3. Use only auxiliary equipment meeting Philips and/or ANSI standards. Use within voltage limits recommended by ballast manufacturer.
 - A. Operate lamp only within specified limits of operation.
 - B. For total supply load refer to ballast manufacturers electrical data.
 - C. These lamps can be used in both probe start and pulse start magnetic ballast. Reference the technical data sheet for proper ANSI ballast code compatibility. Do not operate lamps on electronic ballasts.
 - D. All pulse start mogul based lamps require a socket rated to withstand a 4000 volt pulse.
4. Periodically inspect the outer envelope. Replace any lamps that show scratches, cracks or damage
5. If a lamp bulb support is used, be sure to insulate the support electrically to avoid possible decomposition of the bulb glass.
6. Protect lamp base, socket and wiring against moisture, corrosive atmospheres and excessive heat.
7. Time should be allowed for lamps to stabilize in color when turned on for the first time. This may require several hours of operation, with more than one start. Lamp color is also subject to change under conditions of excess vibration or shock, and color appearance may vary between individual lamps.
8. Lamps may require 10 to 15 minutes to re-light if there is a power interruption. Less than 10 minutes on pulse start ballasts.
9. Take care in handling and disposing of lamps. If an arc tube is broken, avoid skin contact with any of the contents or fragments.

