

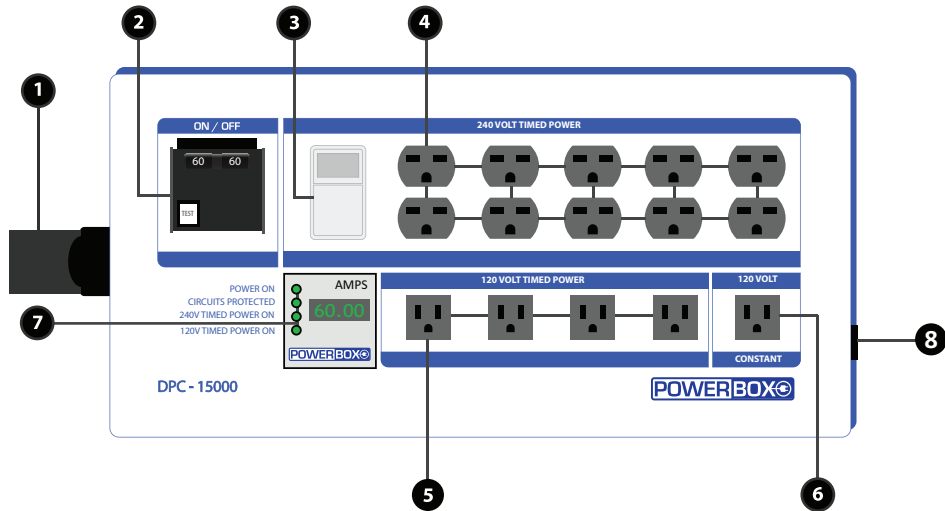

DPC-12000/15000 SERIES INSTALLATION AND OPERATION INSTRUCTIONS

**WARNING: READ ALL INSTRUCTIONS BEFORE INSTALLATION AND USE.
ALWAYS CONSULT A LICENSED ELECTRICIAN FOR INSTALLATION.**

**FIGURE 1
DPC-15000**



**FIGURE 2
DPC-12000**

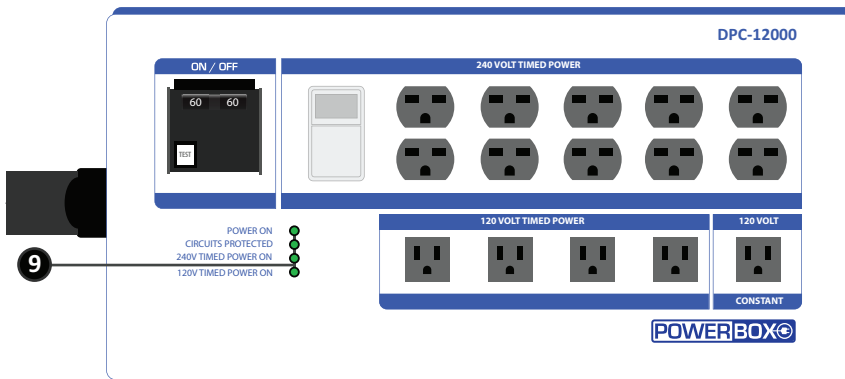

**FIGURE 3
DPC-12000-D**

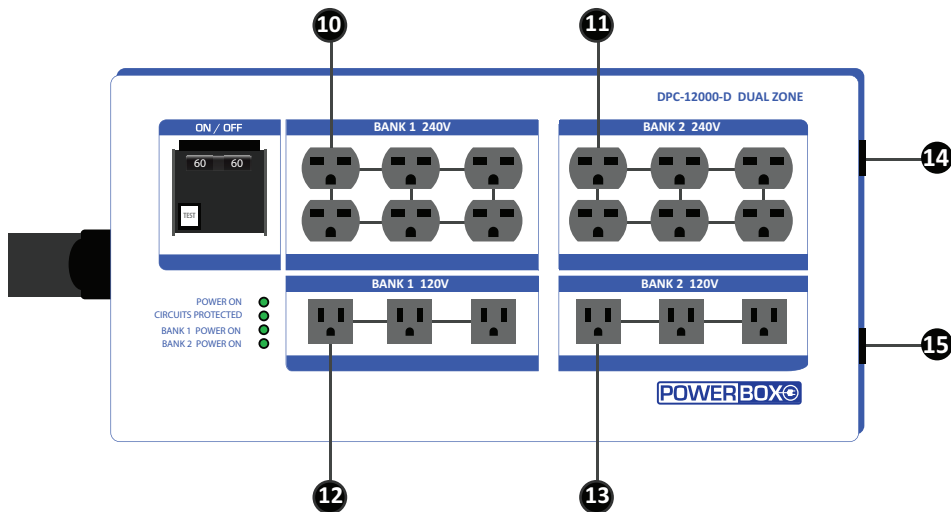

OVERVIEW:

The **Powerbox DPC-12000 and 15000 Series** are 10-outlet lighting controllers that connect to a 4-wire, 240-volt main input, and provide 240-volt and 120-volt output power through 10 NEMA type 6-15 outlets and 5 NEMA type 5-15 outlets. Rated output capacity ranges from 30 amps to 60 amps continuous at 240 Volts, depending on the model. These units contain a microprocessor-controlled GFCI main circuit breaker that provides the ultimate in specialized protection for you and your equipment, when installed properly.

1. **MAIN POWER INPUT.** The DPC-12000 and DPC-15000 series have 4.5' main power cables and come in the following configurations and main connection types:

DPC-15000 (Ten 240-volt outlets, Five 120-volt outlets)

- 50A Capacity, 4-Prong Plug & Play with a NEMA type 14-50P plug (standard 4-prong range plug)
- 50A Capacity, 4-Wire Hardwire
- 60A Capacity, 4-Wire Hardwire

DPC-12000 (Ten 240-volt outlets, Five 120-volt outlets)

- 50A Capacity, 4-Prong Plug & Play with a NEMA type 14-50P plug (standard 4-prong range plug)
- 50A Capacity, 4-Wire Hardwire
- 60A Capacity, 4-Wire Hardwire

DPC-12000-D (Twelve 240-volt outlets, Six 120-volt outlets)

- 30A Capacity, 4-Prong Plug & Play with a NEMA type 14-30P plug (standard 4-prong dryer plug)
- 50A Capacity, 4-Prong Plug & Play with a NEMA type 14-50P plug (standard 4-prong range plug)
- 50A Capacity, 4-Wire Hardwire
- 60A Capacity, 4-Wire Hardwire

2. **GFCI MAIN CIRCUIT BREAKER.** Provides protection to equipment and personnel through a microprocessor-controlled technology that monitors line conditions and downstream appliance conditions for abnormalities that could lead to fire or electrocution. The rating of this breaker will determine the capacity of the unit.
3. **PROGRAMMABLE DIGITAL TIMER.** The programmable digital timer allows the user to control the upper ten 240-volt outlets and the first four 120-volt outlets. The timer allows for up to seven separate program cycles. A typical 12-hour on, 12-hour off cycle, set for every day of the week, will require only one program. Outlets cannot be timed independently; they operate in a group only. See Digital Timer Programming Instructions in Section 3 for details on setting the programs.
4. **240-VOLT TIMED OUTLETS.** The ten 240-volt outlets are controlled by the digital timer and can be programmed to turn on and off according to the program(s) set in the timer. These outlets are designed for running HID lighting loads.
5. **120-VOLT TIMED OUTLETS.** The first four 120-volt outlets are controlled by the digital timer and turn on and off in unison with the 240-volt timed outlets. The 120-volt timed outlets are designed for small loads such as fans and accessories.
6. **120-VOLT CONSTANT OUTLET.** The last 120-volt outlet provides constant power when the main unit is turned on and is provided for running small accessory loads.
7. **DIGITAL AMMETER.** The DPC-15000 series has a digital ammeter that precisely monitors load draw in real time so that you can ensure you don't overload the unit and trip the circuit breaker inadvertently.
8. **OPTIONAL TRIGGER CORD.** This inlet accepts a standard 120-volt trigger cord that can be used to override the built-in timer, in case you want to use another device to control the on/off cycles of the Powerbox.
9. **STATUS INDICATOR LIGHTS.** The DPC-12000 is identical in form and function to the DPC-15000, except the DPC-12000 does not contain the digital ammeter. In its place are four status indicator lights that show when the unit is on and protected.
10. **ZONE 1, 240-VOLT OUTLETS.** The DPC-12000-D is a Dual Zone unit that has two banks of 240-volt outlets. Shown in #10 is Bank 1 of the 240-volt outlets, which are activated when the Bank 1 trigger cord (#14) receives a 120-volt signal.
11. **ZONE 2, 240-VOLT OUTLETS.** The DPC-12000-D is a Dual Zone unit that has two banks of 240-volt outlets. Shown in #11 is Bank 2 of the 240-volt outlets, which are activated when the Bank 2 trigger cord (#15) receives a 120-volt signal.
12. **ZONE 1, 120-VOLT OUTLETS.** The DPC-12000-D has three 120-volt outlets in Zone 1 that provide continuous power when the main unit is powered on. These outlets can optionally be wired to power on in conjunction with the ZONE 1 240-volt outlets, via the trigger cord.
13. **ZONE 2, 120-VOLT OUTLETS.** The DPC-12000-D has three 120-volt outlets in Zone 2 that provide continuous power when the main unit is powered on. These outlets can optionally be wired to power on in conjunction with the ZONE 2 240-volt outlets, via the trigger cord.
14. **ZONE 1 TRIGGER CORD.** This inlet accepts a standard 120-volt trigger cord (included) that when energized, causes the 240-volt outlets in Zone 1 to turn on.
15. **ZONE 2 TRIGGER CORD.** This inlet accepts a standard 120-volt trigger cord (included) that when energized, causes the 240-volt outlets in Zone 2 to turn on.

240-VOLT AC POWER IS EXTREMELY DANGEROUS. OBSERVE ALL CAUTIONS. MISUSE OF THIS DEVICE MAY SUBJECT YOU TO POTENTIALLY FATAL ELECTRIC SHOCK. CONSULT A PROFESSIONAL ELECTRICIAN FOR INSTALLATION. DO NOT PLUG INTO ANY POWER OUTLET OTHER THAN THE INTENDED TYPE. THIS POWERBOX REQUIRES A MAIN CIRCUIT BREAKER UPSTREAM FROM THE DEVICE. PLUG ONLY INTO A PROPERLY GROUNDED AND EARTHED OUTLET.

SECTION 1. MAIN CONNECTION

Your Powerbox is designed to plug directly into a 240-volt, 4-prong range-type outlet for its main power connection (or alternatively to be hard-wired directly to a circuit at the panel.) **Before plugging your Powerbox into an existing main power outlet, make sure that the circuit breaker for the circuit in question is switched to the OFF position and that no power is flowing to the outlet.** Make sure the plug on your Powerbox matches the outlet receptacle you have.

1.1 CONNECTING TO AN EXISTING CIRCUIT

If you already have an existing 240-volt outlet to plug your Powerbox into, it is important to understand the true capacity of that circuit. Most range-type outlets have a 50 Amp, double-pole circuit breaker at the main panel to prevent overloads. Since residential circuit breakers are designed to handle only 80% of their rated capacity when running on a continuous basis, the true amount of current you can receive from a 50 Amp breaker is only 40 Amps continuous. To take full advantage of the 50 Amp continuous capacity of the Powerbox, it is recommended to install a 60 Amp circuit breaker at your panel and the appropriate gauge wiring (either 6 or 4-gauge) to the Powerbox. For more information, see **SECTION 2, INSTALLING A NEW CIRCUIT.**

1.2 TEST CIRCUIT BEFORE CONNECTING POWERBOX

In our experience, we have found that very often, 240-volt outlets are not wired correctly in residential and commercial structures. For this reason, it is highly recommended that you test the voltage at the outlet with an electrical tester before plugging in your Powerbox. Plugging the Powerbox into an outlet that is improperly wired will cause the unit to not function properly and may cause damage to the unit and/or could subject you to dangerous voltages.

With a simple electrical tester, use the two probes to perform the following tests on the circuit to determine if it is wired properly:



4-Wire Connection:

TEST	PROPER RESULT
1+3	120 Volts AC
2+3	120 Volts AC
1+2	240 Volts AC
1+4	120 Volts AC
2+4	120 Volts AC

4-Wire Connection:

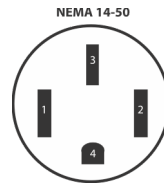

1st Wire: 120-Volt Phase 1
2nd Wire: 120-Volt Phase 2
3rd Wire: Neutral
4th Wire: Ground

If ALL of the tests on your circuit produce the proper result, turn the breaker off and it is safe to plug your Powerbox into the outlet. If ANY of the test combinations do not produce the expected result, the circuit is wired incorrectly. Do not plug in the Powerbox. Have the circuit checked by an electrician.

1.3 CONNECTING THE POWERBOX

Before plugging your Powerbox into the main outlet, make sure the circuit breaker feeding the circuit is switched to OFF and that no live power is flowing to the outlet. Align the prongs of the Powerbox plug with the openings of the receptacle and press firmly until the prongs seat themselves all the way into the outlet. Mount the Powerbox to the wall or set on a flat surface out of the way of potential hazards such as water. Do not plug any appliances into the Powerbox yet. Switch the circuit breaker feeding the circuit to ON. Next, switch the Powerbox Main power on by switching the circuit breaker to the uppermost position. Proceed to **SECTION 3, TIMER PROGRAMMING.**

SECTION 2. INSTALLING A NEW CIRCUIT

If you are installing a new dedicated circuit for your Powerbox, you should be installing a 4-wire 240-volt circuit, which consists of two hot wires, a neutral and a ground wire. You have the choice of 1.) Installing a NEMA 14-50R outlet receptacle for your main Powerbox cord to plug directly into (See **SECTION 2.3A**), or 2.) Installing a junction box that will be used to join the wires from the Powerbox to the incoming wires from the breaker panel (hardwire installation – See **SECTION 2.3B**.) Either way, the materials needed will be the same, up to the point where the circuit terminates to either an outlet or a junction box.

2.1 INSTALL CIRCUIT PROTECTION DEVICE

The DPC-12000 and 15000 series can be wired directly to a live bus bar, or can be installed with an additional circuit breaker upstream from the unit, at your main electrical panel, or sub-panel. It is important to know that most circuit breakers are designated to function at 80% of their rated capacity when running continuous loads. The Powerbox circuit breaker is designed to run at a 100% load. Therefore, if installing a 50 amp Powerbox, it is recommended that you install a 60 Amp, double-pole circuit breaker. If installing a 60 amp Powerbox, it is recommended that you install an 80 amp breaker at the panel. Determine the brand or type of circuit breaker you will need by inspecting your electrical panel. Take a picture of the panel, or remove an old breaker, to have with you when shopping for the circuit breaker. For added safety and enhanced protection, a GFCI circuit breaker is recommended.

2.2 INSTALL PROPERLY GAUGED WIRE

Selecting the appropriate wire gauge is critical for maintaining a safe and reliable installation. If you are installing a 60 amp circuit breaker at the panel, and the distance of your wire run is under 75 feet, you will use 6-gauge wire for all connections. If you are installing an 80 amp circuit breaker and your distance is under 75 feet, you will use 4-gauge wire. If you are installing an 80 amp breaker and the distance is over 75 feet, you would use 2-gauge wire. Do not use aluminum wire. Use the same gauge wire for each of the four conductors. Plan a safe and efficient route from your breaker panel to your Powerbox installation that is as short as practically possible and install the appropriate conduit to house and protect the wire.

2.3A INSTALL OUTLET RECEPTACLE

Install a NEMA 14-50R outlet receptacle by mounting the receptacle in the desired location and terminating conduit from the main panel to the outlet. Connect wires to outlet terminals as per the instructions that come with the outlet. Be sure to tightly connect the wires to the appropriate locations on the terminals of the outlet, as specified. Once complete, refer back to **SECTION 1.2, TEST THE CIRCUIT BEFORE CONNECTING POWERBOX.**

2.3B INSTALL JUNCTION BOX

If installing a Powerbox hardwire model, select a standard metal junction box of sufficient size (roughly 5"x5") where the incoming conduit will terminate and the panel wires will join with the wires from the Powerbox. Mount the junction box securely to the wall. Use Split-Bolt Connectors to join wires together, and once joined, wrap each connection with four turns of self-fusing amalgamating tape, followed by four turns of black electrical tape. When connections are complete, secure the junction box with a cover plate.

BASIC CONNECTION FROM PANEL

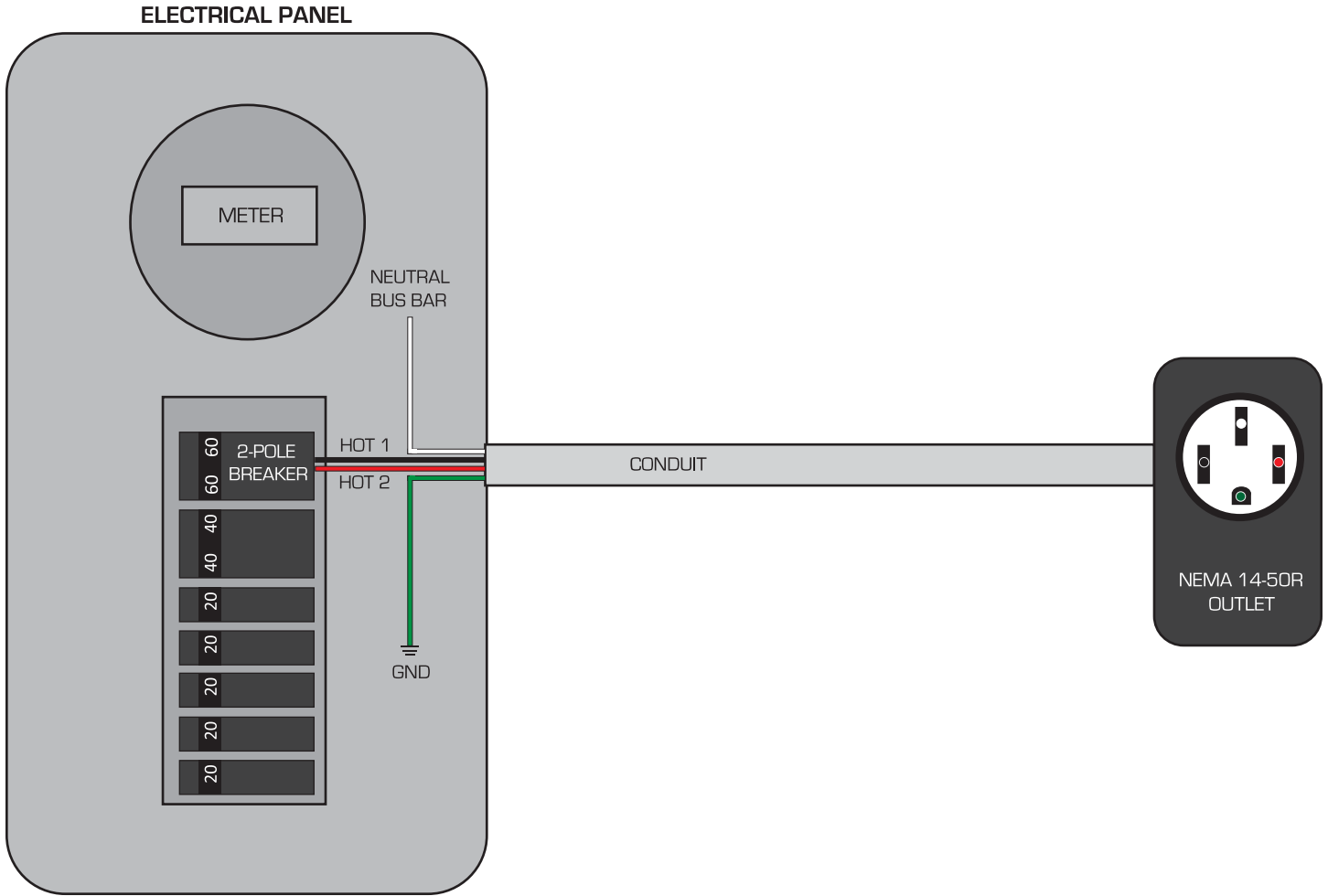

SOME OF THE ITEMS YOU MAY NEED:



60 or 80 Amp double pole circuit breaker.



NEMA 14-50R wall-mount receptacle for plug & play installation.



Standard metal junction box for hardwire installation.



Split-bolt connector used for joining wires in hardwire installation.

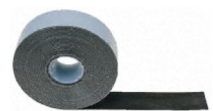

Self-Amalgamating Tape used to wrap and insulate connections made with Split-bolts.

RATED 50 AMPS AT 240 VOLTS AC. INPUT: 240 VAC, 50/60Hz, 50 A. REQUIRES A 4-WIRE CONNECTION: 120 V PHASE 1, 120 V PHASE 2, GROUND, AND NEUTRAL. OUTPUT: 240 VAC AND 120 V VAC. DO NOT EXCEED 15 A ON INDIVIDUAL OUTLETS. DO NOT EXCEED 50 A COMBINED ON ALL OUTLETS. FOR INDOOR USE ONLY. DO NOT OPEN UNIT - RISK OF ELECTROCUTION. OPENING UNIT VOIDS WARRANTY. READ ENTIRE INSTRUCTION MANUAL BEFORE INSTALLATION. IMPROPER INSTALLATION CAN RESULT IN FIRE, SHOCK, OR MAY DAMAGE UNIT. MORE INFORMATION AND INSTRUCTIONS AVAILABLE AT WWW.POWERBOXINC.COM.

MADE IN THE U.S.A.



CONFORMS TO UL STD 1640
 CERTIFIED TO CAN/CSA STD C22.2#14-10



Intertek
 4001996

SECTION 3. TIMER PROGRAMMING INSTRUCTIONS

The built-in programmable digital timer is flexible and easy to setup. You can program up to 7 ON/OFF cycles for any individual day, or for every day of the week. For instance, it would take one program to set the Powerbox to go on and off once per day, every day of the week.

1. Pop open the door of the Digital Timer with a small screw driver.
2. Ensure the ON/OFF switch at the bottom of the Digital Timer is set to the ON position.
3. Reset the Digital Timer by using a small paperclip to depress the recessed RESET button (small round hole).

SETTING THE CLOCK

4. The Digital Timer displays the time in 24-hour format by default following a reset. To change to 12-hour format, press the MIN and HOUR buttons simultaneously and briefly (0:00 display = 24-hour format, 12:00 display = 12-hour format).
5. Set the time using the HOUR and MIN buttons. If you have selected the 12-hour format, ensure that PM appears on the screen when an afternoon time is displayed.
6. Set the day by using the DAY button.
7. Press one of the control buttons or close the Digital Timer door to return to normal operation.

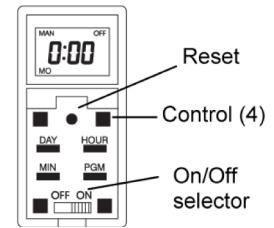

PROGRAMMING THE DIGITAL TIMER

8. You can set up to 7 different programs with the digital timer. However, for a standard routine where the unit comes on and off at the same time every day, you only need to set one program, and select all days of the week. To set a program, you need to enter its start time (ON) and its end time (OFF).
 - a. Pry the Digital Timer door open using a small screwdriver.
 - b. Press the PGM button once, and program number 1 (P1) and its On time (ON) will appear. -- will appear instead of the time if the program is not set (inactive).
 - c. Press the DAY button to select the day to which you want to apply the program. If you want to apply the program to every day of the week, press DAY until all the days are displayed. This will count as only 1 program.
 - d. Press the HOUR and MIN buttons to set the ON time (time when you want devices to turn ON). If you have selected the 12-hour format, ensure that PM appears on the screen when an afternoon time is displayed.
 - e. After you have programmed the ON time, press the PGM button briefly to display the OFF time (time when you want the devices to turn OFF).
 - f. By default, the same DAY(s) you selected for the ON time will be displayed for the OFF time.
 - g. Press the HOUR and MIN buttons to set the OFF time (time when you want devices to turn OFF). If you have selected the 12-hour format, ensure that PM appears on the screen when an afternoon time is displayed.
 - h. To set another program, repeat steps (b) through (f). Programs that are not set will remain inactive.
 - i. Press one of the control buttons or close the switch door to return to normal operation.

SELECTING THE OPERATING MODE

9. The Digital Timer has 2 operating modes: manual (MAN) and automatic (AUTO). To switch modes, press and hold the switch door in for 3 seconds.
 - a. Manual Mode. The Digital Timer operates as a regular switch. Briefly press the switch door in to turn devices On or Off. The mode (MAN) and state (ON or OFF) are displayed.
 - b. Automatic Mode. The Digital Timer follows the programmed schedule. The mode (AUTO), state (ON or OFF) and current program number are displayed. To temporarily override the programmed schedule, briefly press the switch door. The new state (ON or OFF) will flash to show that this state is temporary. The override remains in effect until you press the switch door again or until the beginning of the next program.

PROGRAMMING FOR USE IN CONJUNCTION WITH FLIPBOXES

10. When using a Flipbox in conjunction with your Powerbox lighting controller, it is recommended to power the ballasts off for 10 minutes during each flip cycle during the time the flip is set to occur. For instance, if your light flip times are 12:00 AM and 12:00 PM, you would program your Powerbox lighting controller's timer as follows:

Program Powerbox Lighting Controller as follows:

P1 ON Time: 12:05 PM, P1 OFF Time: 11:55 PM
P2 ON Time: 12:05 AM P2 OFF Time: 11:55 AM
Be sure to set both P1 and P2 for ALL days of the week.

Program the Flipbox timer as follows:

P1 ON Time at 12:00 AM and P1 OFF Time and 12:00 PM.
Be sure to set P1 for ALL days of the week.

TROUBLE SHOOTING GUIDE

BLANK TIMER DISPLAY: Verify there is power to the unit. Ensure the ON/OFF selector switch on the Digital Timer is set to ON. Reset the Digital Timer using a small paperclip.

TIMER DISPLAY HARD TO READ OR APPEARS FADED OUT: Verify that the neutral wire is properly connected at the main panel and at the point where it connects to the Powerbox. If timer display still appears faint, the internal backup battery may need recharging. Leave the unit connected to the main power and make sure the recessed switch at the bottom of the timer is set to the ON position. Leave the unit on for 90 minutes to give the battery time to fully charge. Check the display again and it should appear normal.

PROGRAMS DO NOT RUN AS EXPECTED: Make sure the Digital Timer is properly programmed. Note that -- indicates an inactive program, 00:00 indicates midnight. If the Timer has been configured for 12-hour format, check that PM appears on the left side of the screen when an afternoon time is displayed. Make sure the timer is in AUTO mode.

CANNOT SWITCH BETWEEN 24-HOUR and 12-HOUR FORMAT: First, press one of the control buttons so that MAN or AUTO appears on the display.

TIMED OUTLETS DON'T WORK / WON'T TURN ON: Check that the main circuit breaker is turned on. Check that the recessed switch under the timer front panel is switched ON. Check that the timer display reads ON. Check the main connection and ensure that all wires are connected properly.

TIMED OUTLETS DON'T WORK / ONE CONSTANT OUTLET WORKS: One of the 120V hot legs is missing or improperly connected. Turn off the power at the main breaker and check all connections.