

MR-11 SERIES (2W; Replaces 20-Watt Halogen)

Description:

The MR-11 LED 2W lamp has been redesigned to better fit into standard, low voltage, MR-11 fixtures. These LED's are **thermally engineered to operate in enclosed fixtures**, and they also feature our own enhanced **ESD (Electro-Static Discharge) Protection (IEC-61000-4-2)**, as well as our own built-in **Heat Overload Protection Technology** - which gives you added security by automatically cooling down (and reducing lumens output) only when exposed to extreme heat (air temperatures above 125°F). Best of all, there is no color shift when lumens output is reduced, and overall lamp life is improved. When extreme temperatures drop below 125°F, full lumens output will automatically resume.

Specifications/Features:

- Enhanced ESD (Electro-Static Discharge) Protection (IEC-61000-4-2)
- Built-In Heat Overload Protection Technology
- UL Listed & FCC Compliant
- Available In 2200, 2700, 3000, & 5700 Kelvin Temperatures, as well as Red, Green, Blue, & Amber
- Available In 15°, 30°, & 60° Beam Angles
- 2 Watts; 0.4A Max Current
- 8-25VAC
- IP61
- 120 Lumens (2700K)
- CRI: 85
- CREE Chipset
- 50,000 hours lamp life
- Fully potted PC board
- Dimmable with most magnetic transformers
- Patent Pending

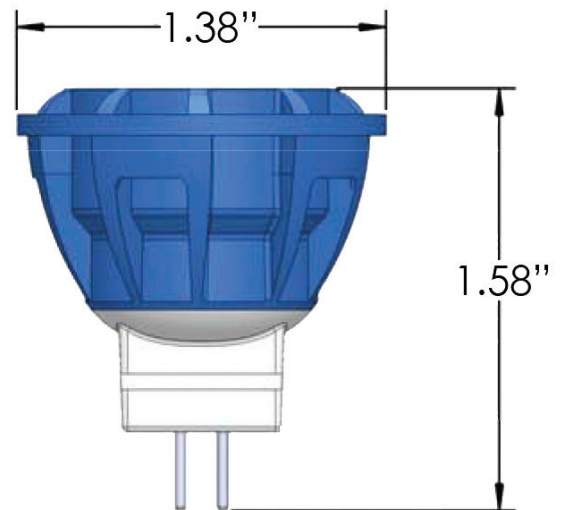

PART NUMBER: MR11 2 XXXX XX

2200
2700
3000
5700

KELVIN TEMPERATURE

RED = Red
GREEN = Green
BLUE = Blue
AMBER = Amber

BEAMSPREAD 15 = 15 degree
30 = 30 degree
60 = 60 degree