

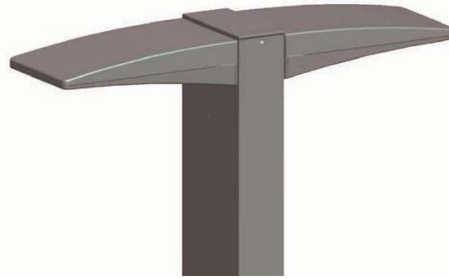

LED BOLLARD INSTALLATION INSTRUCTIONS

Thank you for buying RAB lighting fixtures. Our goal is to design the best quality products to get the job done right. We'd like to hear your comments. Call the Marketing Department at 888-RAB-1000, or email: marketing@rablighting.com



IMPORTANT

READ CAREFULLY BEFORE INSTALLING FIXTURE. RETAIN THESE INSTRUCTIONS FOR FUTURE REFERENCE.

RAB fixtures must be wired in accordance with the National Electrical Code and all applicable local codes. Proper grounding is required for safety. THIS PRODUCT MUST BE INSTALLED IN ACCORDANCE WITH THE APPLICABLE INSTALLATION CODE BY A PERSON FAMILIAR WITH THE CONSTRUCTION AND OPERATION OF THE PRODUCT AND THE HAZARDS INVOLVED.

WARNING: Make certain power is OFF before installing or maintaining fixture.

LOCATION

1. The Bollard should be mounted to a firm level surface.
2. Anchor bolts may be used in new concrete installations. Use the provided template.
3. For all other applications use anchors suitable for the mounting surface.

ANCHOR BOLTS INSTALLATION

CAUTION: Install according to all applicable local codes.

1. Install two **Anchor Bolts** in concrete foundation (by others) using the template provided. **Anchor Bolts** should protrude no more than 3".

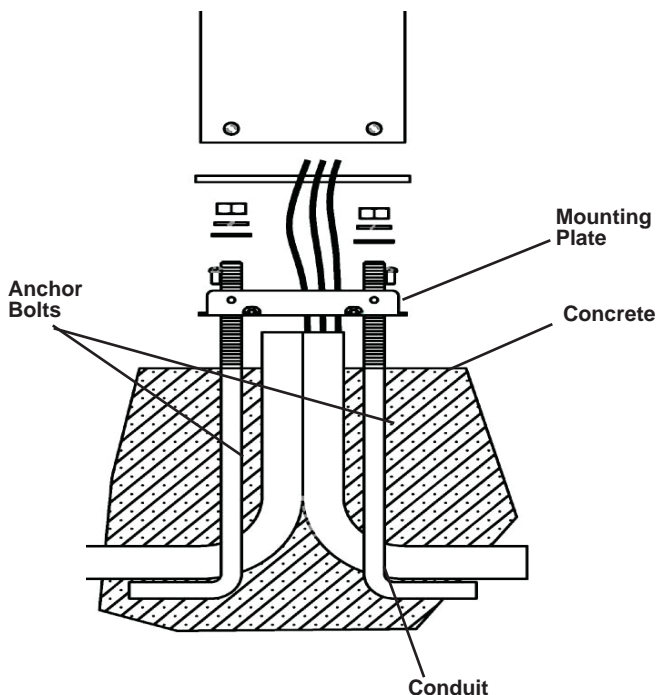

MOUNTING FIXTURES

Depending on your model one or two fixtures can be mounted to each bollard.

1. Loosen three **Door Screws** and remove the **Door**.
2. Use the two #10-24 x 3/4" **Mounting Screws** to thread into the **Bollard** extrusion.
3. Use the nuts and lockwashers provided to secure the screws from inside the **Bollard**. Tighten securely.
4. Make sure the **Housing Gaskets** are properly positioned.
5. Make electrical connections from the supply wires to the fixtures using approved connectors. Strain relief the wires.
6. Replace the **Door**. Tighten screws.
7. Install the **Bollard Cap** and **Gasket** and tighten the two set screws.

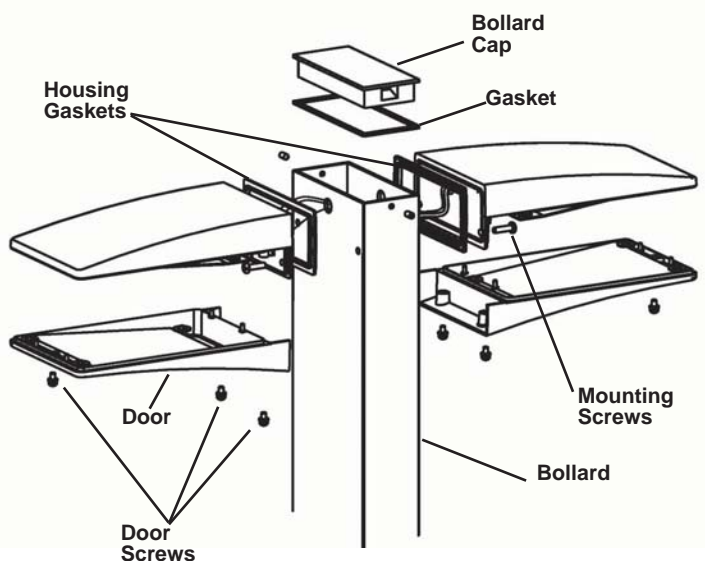

LED BOLLARD INSTALLATION INSTRUCTIONS

MOUNTING PLATE

Assemble fixture(s) to bollard before mounting the Bollard to the Mounting Plate.

1. Place the **Mounting Plate** over **Anchor Bolts**.
2. Use four **Leveling Screws** or shims to level the **Mounting Plate**.
3. Tighten assembly using the washers, lockwashers and nuts provided.
4. Make sure supply leads extend far enough to make fixture connections.
5. Slide **Gasket** around the **Mounting Plate**.
6. Use the four **Mounting screws** to mount the **Bollard** to the **Mounting Plate**. Tighten securely.

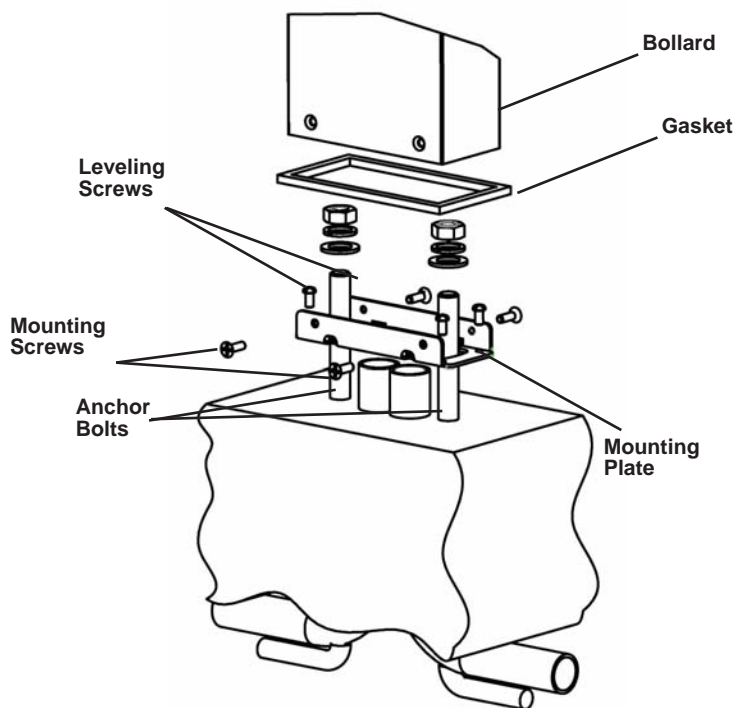

WIRING

All units may operate 120V-240V at 50 or 60Hz.

1. Connect the black fixture lead to the (+) LINE supply lead.
2. Connect the white fixture lead to the (-) COMMON supply lead.
3. Connect the bare copper Ground wire from fixture to supply ground.

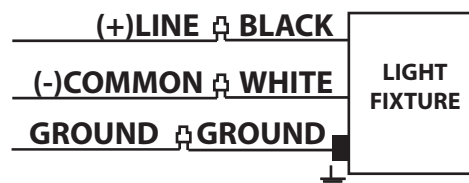

CLEANING & MAINTENANCE

CAUTION: Be sure fixture temperature is cool enough to touch. Do not clean or maintain while fixture is energized.

1. Clean glass lens with non-abrasive glass cleaning solution.
2. Do not open fixture to clean the LED. Do not touch the LED.

MOUNTING PLATE DIMENSIONS

NOT ACTUAL SIZE. For actual size template see last page of instructions .

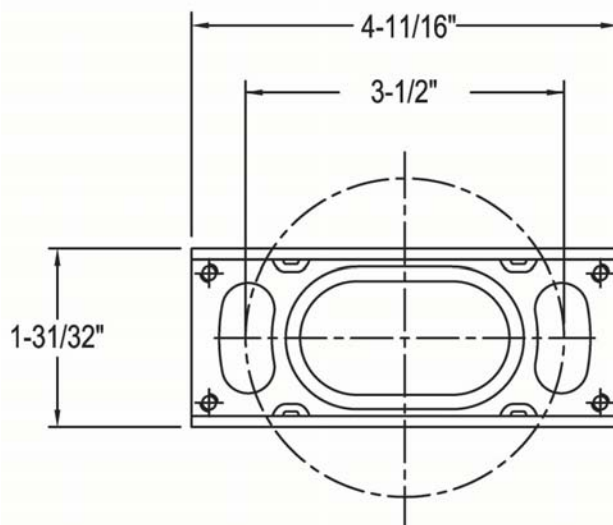

The design of the LED Bollard is protected by U.S. patent D599,050; D599,049 and patents pending in Canada, China and Taiwan.

Note: These instructions do not cover all details or variations in equipment nor do they provide for every possible situation during installation, operation or maintenance.

LED BOLLARD INSTALLATION INSTRUCTIONS

ANCHOR BOLT TEMPLATE FOR BLED BOLLARD
Actual size if this page is printed on 8 1/2" x 11".

