

**Specification**

<b>Nominal Voltage</b>	12V
<b>Nominal Capacity</b>	Equivalent to a 14Ah SLA
<b>Approximate Weight</b>	1.68 lbs (.763 kg)
<b>Cold Cranking Amps</b>	210
<b>Self Discharge</b>	Less than 3% per month
<b>Charge Method</b> (Constant Voltage)	
<b>Cycle Use</b> (Repeating Use)	
Initial Current	14 A Max.
Control Voltage	14.4 V
<b>Float Use</b>	
Control Voltage	13.4 - 13.5 V

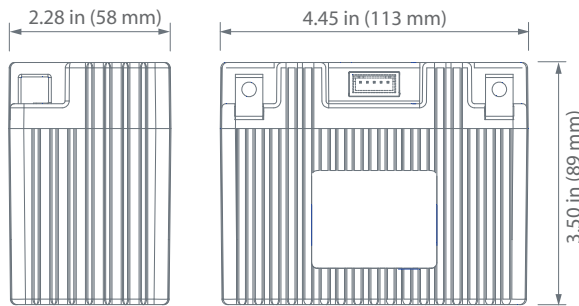

**Physical Dimensions: in (mm)**



**L:** 4.45 in (113 mm)  
**W:** 2.28 in (58 mm)  
**H:** 3.5 in (89 mm)

Tolerances are +/- 0.04 in. (+/- 1mm) and +/- 0.08 in. (+/- 2mm) for height dimensions. All data subject to change without notice.

**Polarity**



- Extreme-rate LiFePO4 cell technology
- Ultra light, One-fifth the weight of a lead-acid battery on average
- Zero sulfation for longer service life
- Drop-in replacement for your OEM battery
- Military spec carbon composite case
- Faster cranking for better starts
- Super-fast recharge rate
- No explosive gasses during charge - no lead, no acid
- Environmentally friendly - just discharge and recycle



www.upgi.com

1720 Hayden Drive | Carrollton, Texas 75006 | P 469.892.1122 | T 866.892.1122 | F 469.892.1123 | sales@upgi.com